

P-8527-1

15202

SCALE 1:1

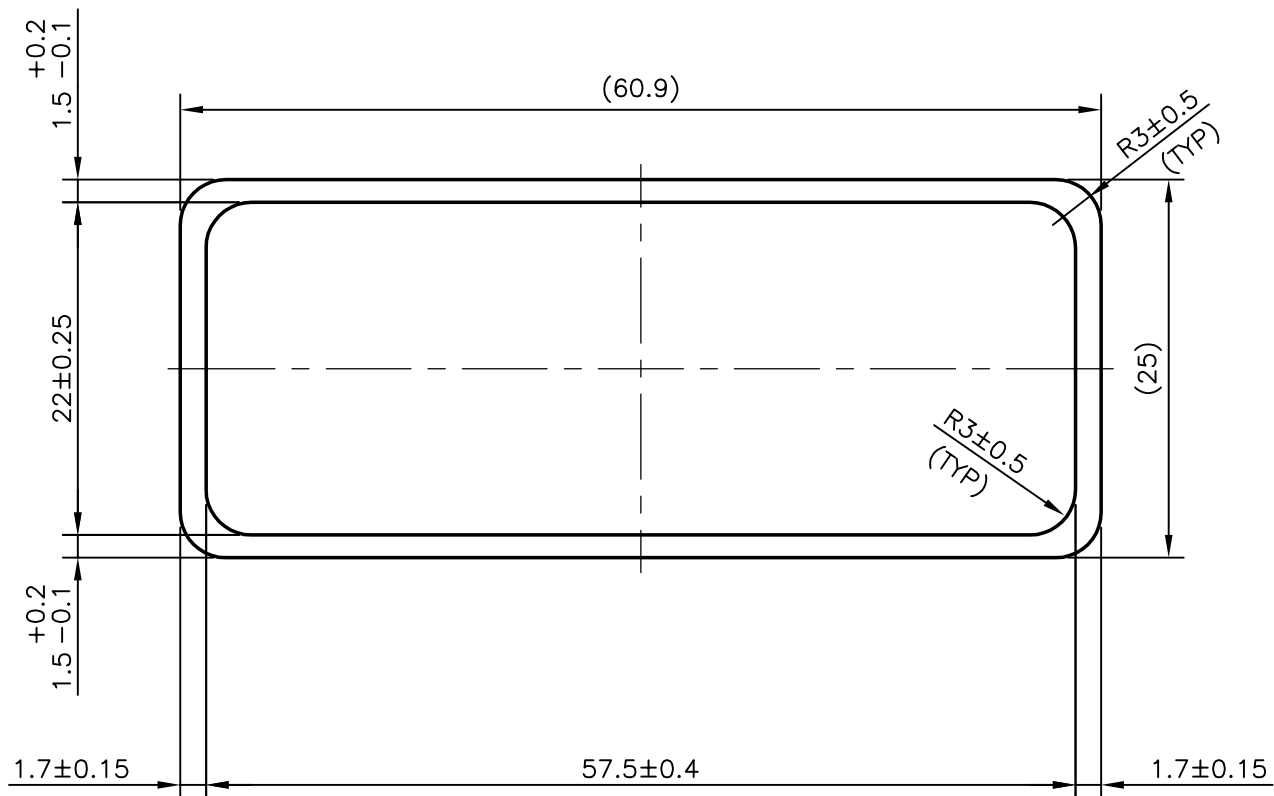

SYMBOL OF QUALITY
AN ISO 9001 COMPANY

JINDAL ALUMINIUM LTD.
BANGALORE-560073 (INDIA)

	NAME	DATE
DRAWN	PRASANNA.H	06-09-2008
CHECKED		
APPROVED		

1. ALL DIMENSIONS ARE IN mm.
2. ROUND OFF ALL SHARP CORNERS WITH 0.40 mm.
3. TOLERANCES WILL BE AS PER DIN EN 12020-2, UNLESS OTHERWISE SPECIFIED

SCALE	2:1
AREA mm ²	257.5
PERIMETER mm.	166.65
WEIGHT kg/m	0.695

PARTY'S NAME	ZARGES TUBESCA INDIA PVT. LTD., ANDHRA PRADESH
PARTY'S DRAWING No.	11002
ALLOY & TEMPER	6063 T66
DESCRIPTION	RECTANGULAR TUBE

DRAWING No.	SECTION No.
P-8527-1	-
15202	15202