

P-8529-1

15203

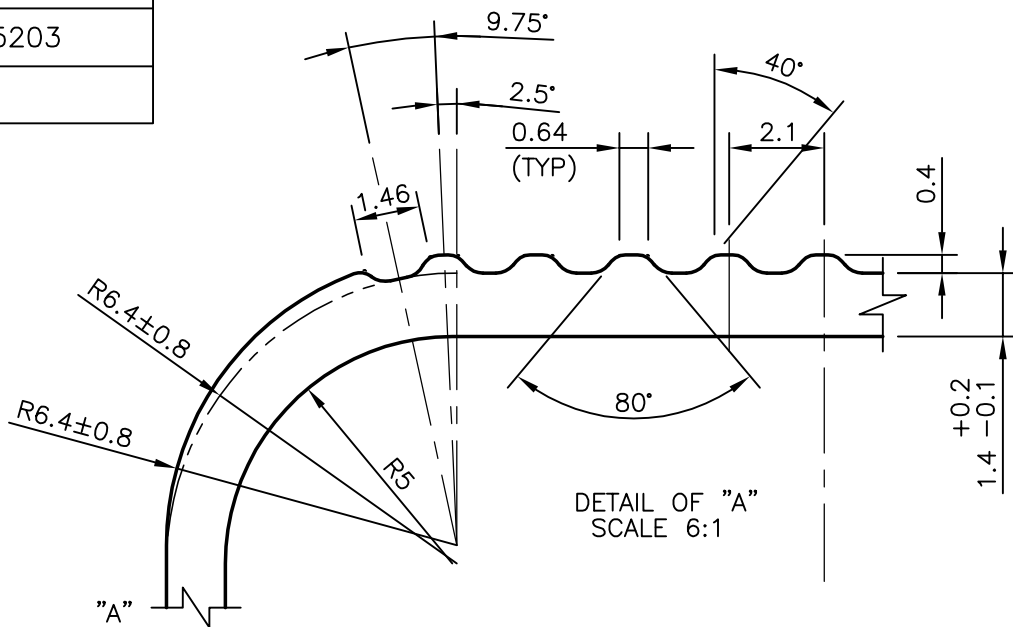

DETAIL OF "A"  
SCALE 6:1

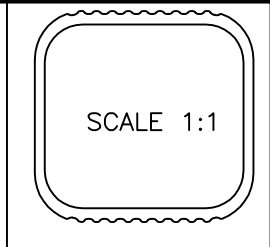
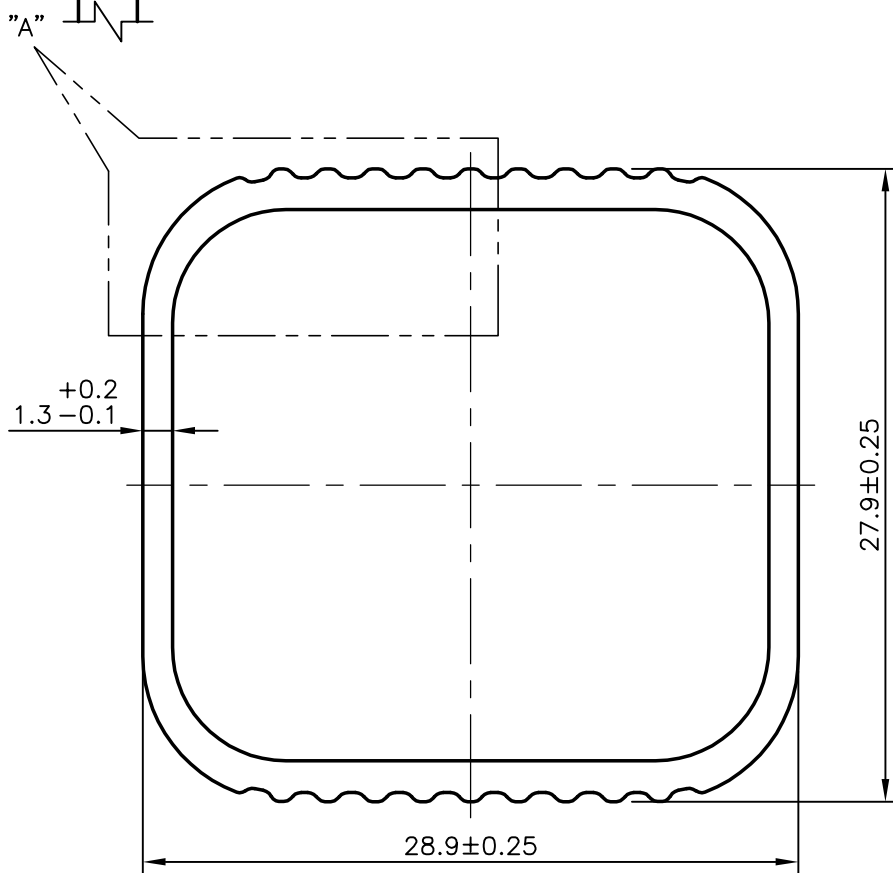

SYMBOL OF QUALITY  
AN ISO 9001 COMPANY

**JINDAL ALUMINIUM LTD.**  
BANGALORE-560073 (INDIA)

	NAME	DATE
DRAWN	PRASANNA.H	11-09-2008
CHECKED		
APPROVED		

1. ALL DIMENSIONS ARE IN mm.
2. ROUND OFF ALL SHARP CORNERS WITH 0.40 mm.
3. TOLERANCES WILL BE AS PER DIN EN 12020-2 UNLESS OTHERWISE SPECIFIED

SCALE	3:1
AREA mm <sup>2</sup>	144.674
PERIMETER mm.	107.612
WEIGHT kg/m	0.391

PARTY'S NAME	ZARGES TUBESCA INDIA PVT. LTD., ANDHRA PRADESH
PARTY'S DRAWING No.	11001
ALLOY & TEMPER	6063 T66
DESCRIPTION	MISC. TUBE

DRAWING No.	SECTION No.
P-8529-1	-
15203	15203