

P-6734

S1863

15207

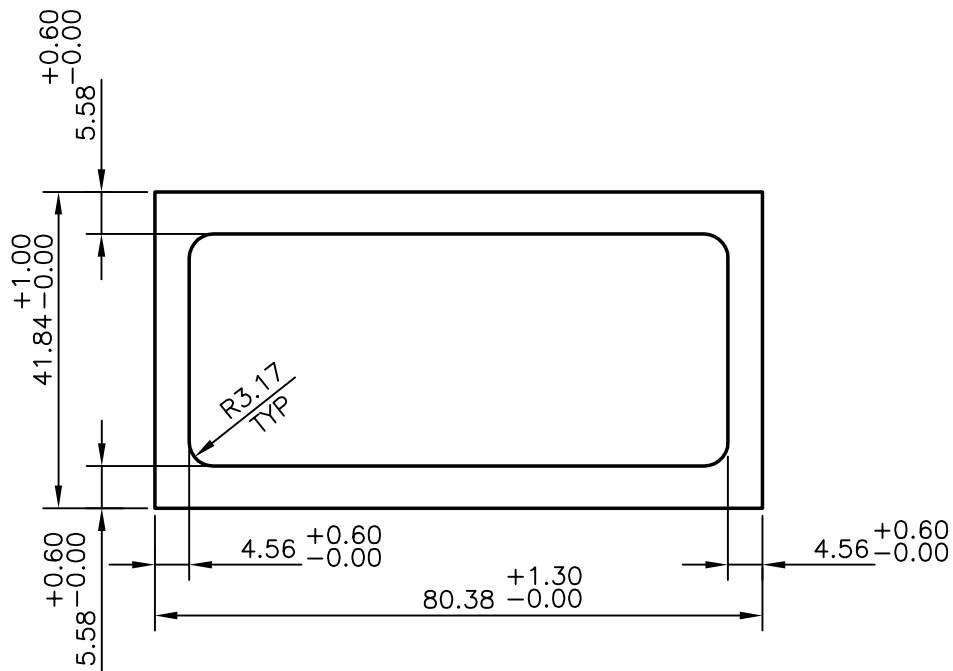

MAINTAIN ALL DIMENSIONS NEARER TO NOMINAL VALUE



SYMBOL OF QUALITY
AN ISO 9001 COMPANY

JINDAL ALUMINIUM LTD.
BANGALORE-560073 (INDIA)

| | NAME | DATE |
|----------------------|-------------|------------|
| DRAWN | RAGHAVENDRA | 09-10-2006 |
| CHECKED | | |
| APPROVED | | |
| SCALE | | 1:1 |
| AREA mm ² | | 1185.468 |
| PERIMETER mm. | | 244.44 |
| WEIGHT kg/m | | 3.201 |
| DRAWING No. | SECTION No. | |
| P-6734 | - | |
| S1863 | S1863 | |
| 15207 | 15207 | |
| | | |
| | | |

1. ALL DIMENSIONS ARE IN mm.
2. ROUND OFF ALL SHARP CORNERS WITH 0.40 mm.
3. TOLERANCES WILL BE AS PER IS:6477-1983 UNLESS OTHERWISE SPECIFIED

| | |
|---------------------|--|
| PARTY'S NAME | MARVEL MACHINE TOOL ACCESSORIES, CHENNAI |
| PARTY'S DRAWING No. | B12-06-0 |
| ALLOY & TEMPER | 6063 T5 |
| DESCRIPTION | MISC. TUBE |