

P-9730

15211

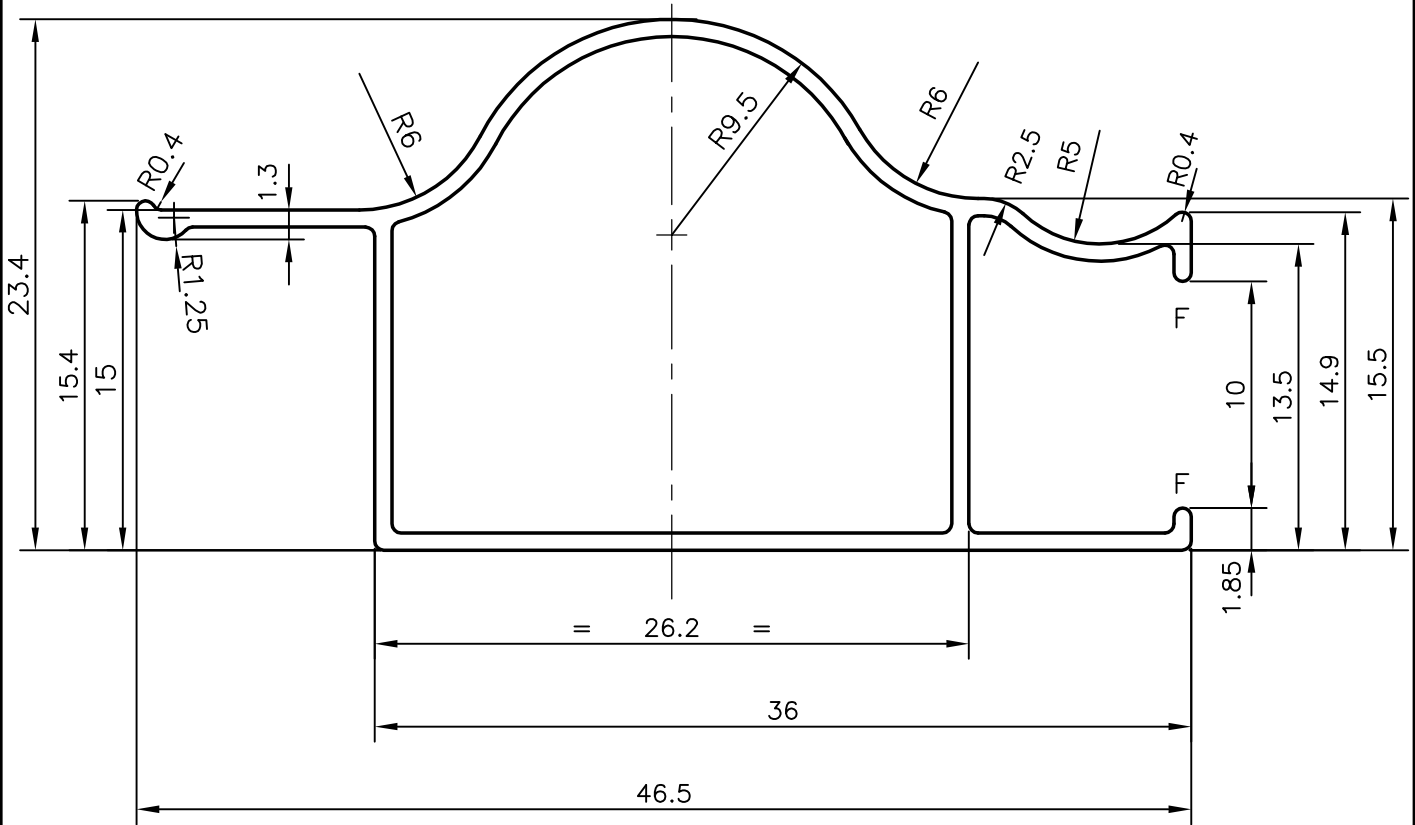

1. F = FULL RADIUS (2)
2. GENERAL WALL THICKNESS:- 0.76 mm.
3. WEIGHT OF 3658 mm. LONG PIECE:- 0.915 kg (AVERAGE)

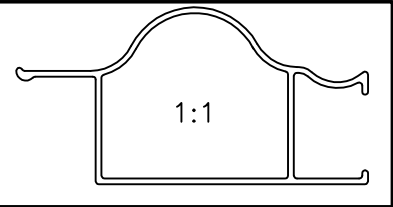

SYMBOL OF QUALITY
AN ISO 9001 COMPANY

JINDAL ALUMINIUM LTD.
BANGALORE-560073 (INDIA)

	NAME	DATE
DRAWN	J.P.KAUSHIK	09-01-2010
CHECKED		
APPROVED		

1. ALL DIMENSIONS ARE IN mm.
2. ROUND OFF ALL SHARP CORNERS WITH 0.40 mm.
3. TOLERANCES WILL BE AS PER IS:6477-1983, UNLESS OTHERWISE SPECIFIED

SCALE	3:1
AREA mm ²	92.557
PERIMETER mm.	155.241
WEIGHT kg/m	0.250

PARTY'S NAME	GENERAL CATEGORY, COCHIN MARKET
PARTY'S DRAWING No.	AS PER SAMPLE
ALLOY & TEMPER	HE9 WP
DESCRIPTION	MISC. TUBE

DRAWING No.	SECTION No.
P-9730	-
15211	15211