

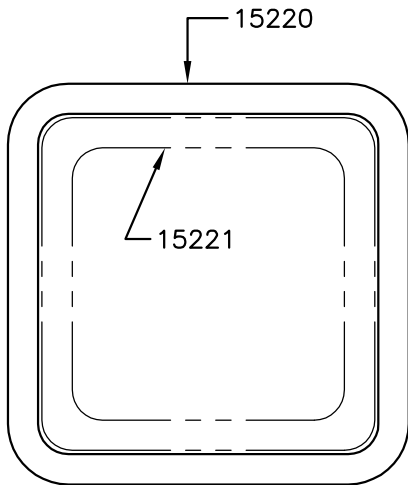

P-10038-1
X1280
15220

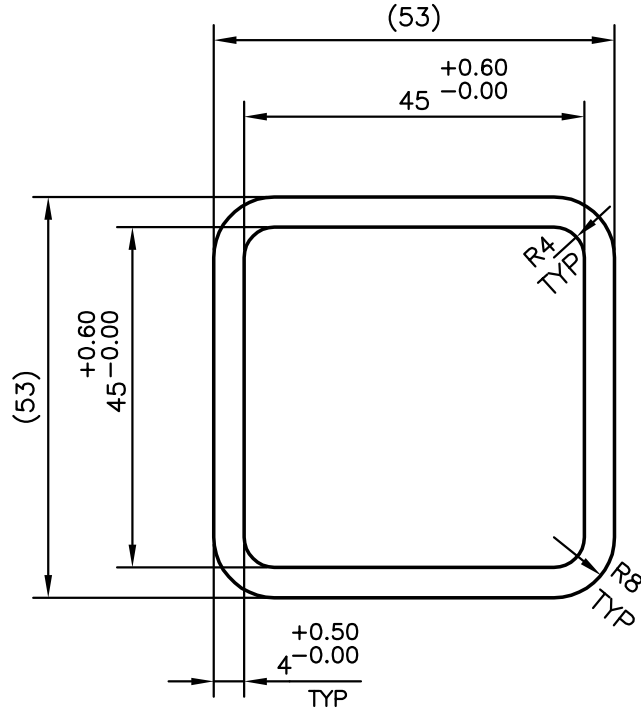

ISSUE-2 TOLERANCE ADDED

 SYMBOL OF QUALITY AN ISO 9001 COMPANY	JINDAL ALUMINIUM LTD. BANGALORE-560073 (INDIA)	DRAWN	NAME	DATE
		CHECKED	J.P.KAUSHIK	19-06-2010
		APPROVED		
1. ALL DIMENSIONS ARE IN mm. 2. ROUND OFF ALL SHARP CORNERS WITH 0.40 mm. 3. TOLERANCES WILL BE AS PER IS:6477-1983 UNLESS OTHERWISE SPECIFIED		SCALE		1:1
		AREA mm ²		742.796
		PERIMETER mm.		198.265
PARTY'S NAME JANARDAN INDUSTRIES, PUNE		WEIGHT kg/m		2.006
		DRAWING No.	SECTION No.	
PARTY'S DRAWING No. AS PER SKETCH		P-10038-1	-	
		X1280	X1280(ISSUE-2)	
ALLOY & TEMPER 6061 T6		15220	15220	
		DESCRIPTION		SQUARE TUBE WITH CORNER RADII