

P-10336-1
S2671
15223

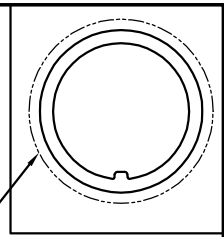

EXPOSED SURFACE

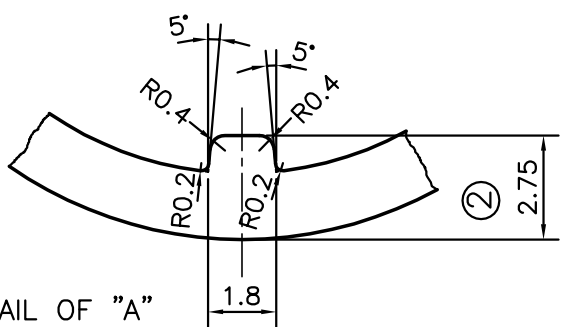

DETAIL OF "A"
SCALE 5:1

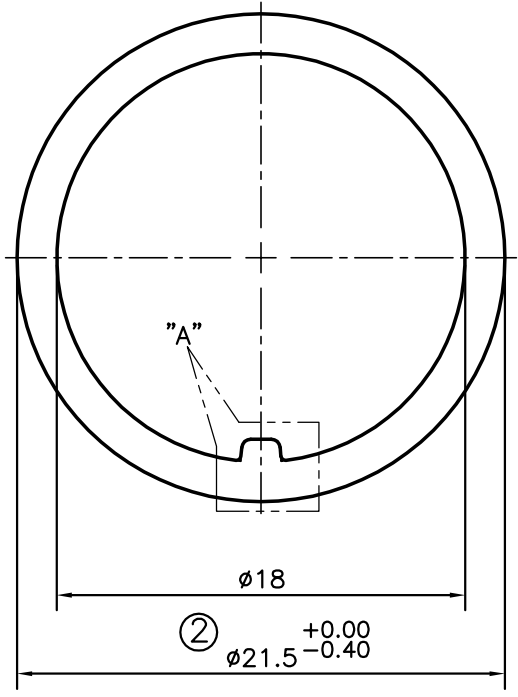

ISSUE-2

OD CHANGED FROM $\phi 21.2$ TO $\phi 21.5$ mm & DIMENSIONS CHANGED FROM 2.6 TO 2.75mm & WEIGHT ALSO CHANGED FROM 0.270 kg/M TO 0.298kg/M

 SYMBOL OF QUALITY AN ISO 9001 COMPANY	JINDAL ALUMINIUM LTD. BANGALORE-560073 (INDIA)	NAME		DATE
		DRAWN	J.P.KAUSHIK	04-10-2010
1. ALL DIMENSIONS ARE IN mm. 2. ROUND OFF ALL SHARP CORNERS WITH 0.4 mm. 3. TOLERANCES WILL BE AS PER IS:6477-1983 UNLESS OTHERWISE SPECIFIED		CHECKED		
		APPROVED		S.S.GARG
PARTY'S NAME YSL ELECTRONICS, BANGALORE		SCALE		3:1
		AREA mm ²		110.237
PARTY'S DRAWING No. YSL-458-7-1 REV-1		PERIMETER mm.		67.544
		WEIGHT kg/m		0.298
ALLOY & TEMPER HE9 WP		DRAWING No.		SECTION No.
		P-10336-1		
DESCRIPTION MISC. TUBE		S2671		S2671(ISSUE-2)
		15223		15223