

P-11873

S3363

15241

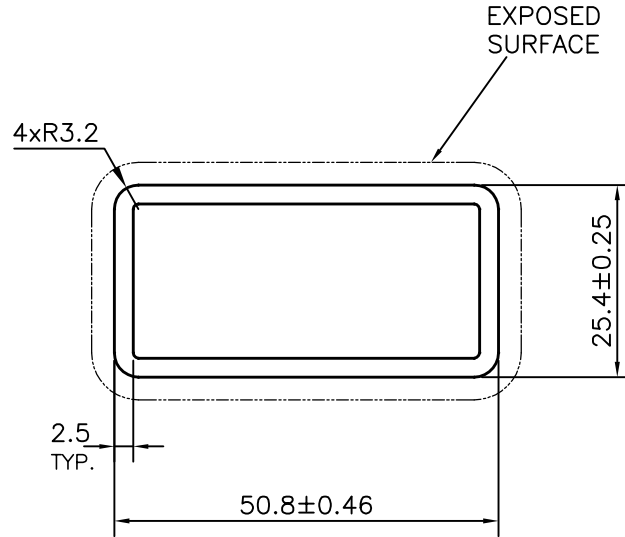

SYMBOL OF QUALITY
AN ISO 9001 COMPANY

JINDAL ALUMINIUM LTD.
BANGALORE-560073 (INDIA)

	NAME	DATE
DRAWN	PARVESH	23-06-2012
CHECKED		
APPROVED	S.S.GARG	28-06-2012

1. ALL DIMENSIONS ARE IN mm.
2. ROUND OFF ALL SHARP CORNERS WITH 0.40 mm.
3. TOLERANCES WILL BE AS PER IS:6477-1983, UNLESS OTHERWISE SPECIFIED

SCALE	1:1
AREA mm ²	347.631
PERIMETER mm.	146.906
WEIGHT kg/m	0.939

PARTY'S NAME	DIGITAL JUICE ANIMATIONS PVT. LTD., BANGALORE
PARTY'S DRAWING No.	DE-JIB-0010017
ALLOY & TEMPER	6063 T6
DESCRIPTION	RECTANGULAR TUBE WITH CORNER RADII

DRAWING No.	SECTION No.
P-11873	-
S3363	S3363
15241	15241