

P-13614

X1766

15243

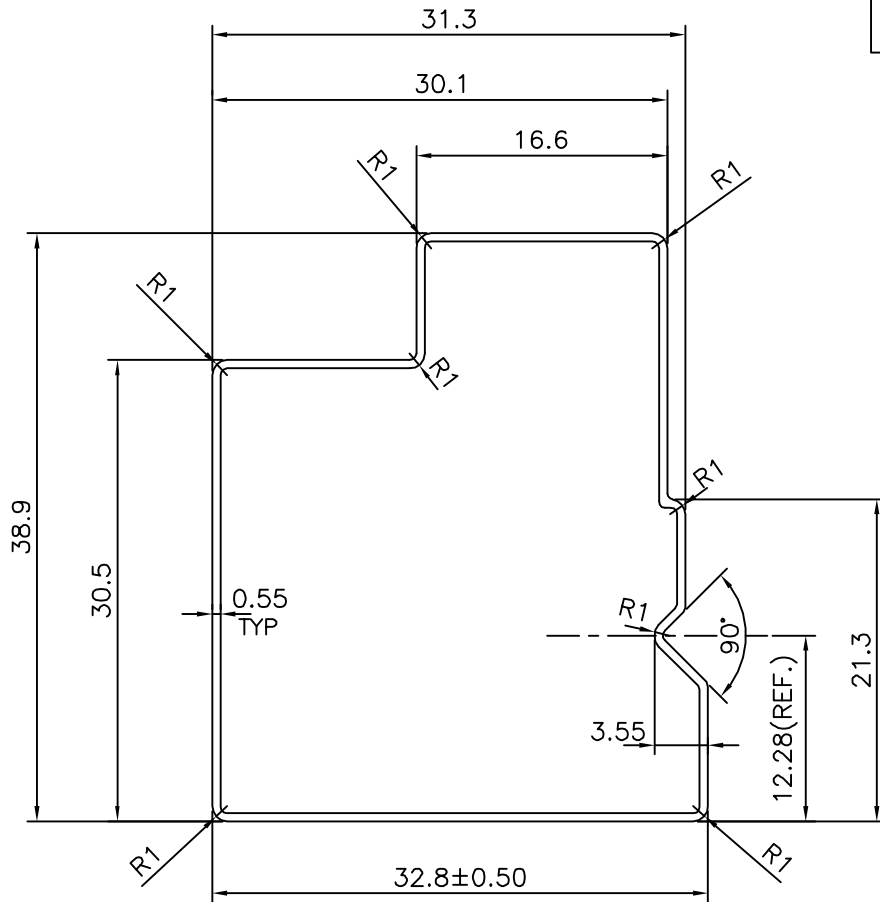
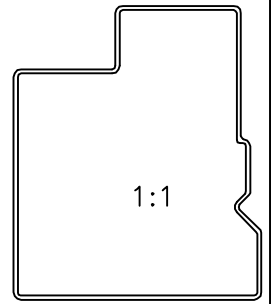

SYMBOL OF QUALITY
AN ISO 9001 COMPANY

JINDAL ALUMINIUM LTD.
BANGALORE-560073 (INDIA)

	NAME	DATE
DRAWN	J.P.KAUSHIK	27-05-2014
CHECKED		
APPROVED	S.S.GARG	10-06-2014

1. ALL DIMENSIONS ARE IN mm.
2. ROUND OFF ALL SHARP CORNERS WITH 0.40 mm.
3. TOLERANCES WILL BE AS PER IS:6477-1983, UNLESS OTHERWISE SPECIFIED

SCALE	2:1
AREA mm ²	76.605
PERIMETER mm.	140.764
WEIGHT kg/m	0.207

PARTY'S NAME: PADMAWATI EXTRUSION PVT. LTD., DELHI

DRAWING No. SECTION No.

PARTY'S DRAWING No.: AS PER DRAWING

P-13614 -

ALLOY & TEMPER: HE9 WP

X1766 X1766

15243 15243

DESCRIPTION: MISC. SECTION