

P-15430

15254

EXPOSED  
SURFACE

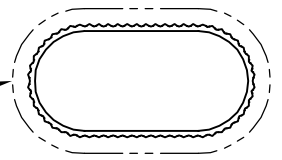

SCALE: - 1:1

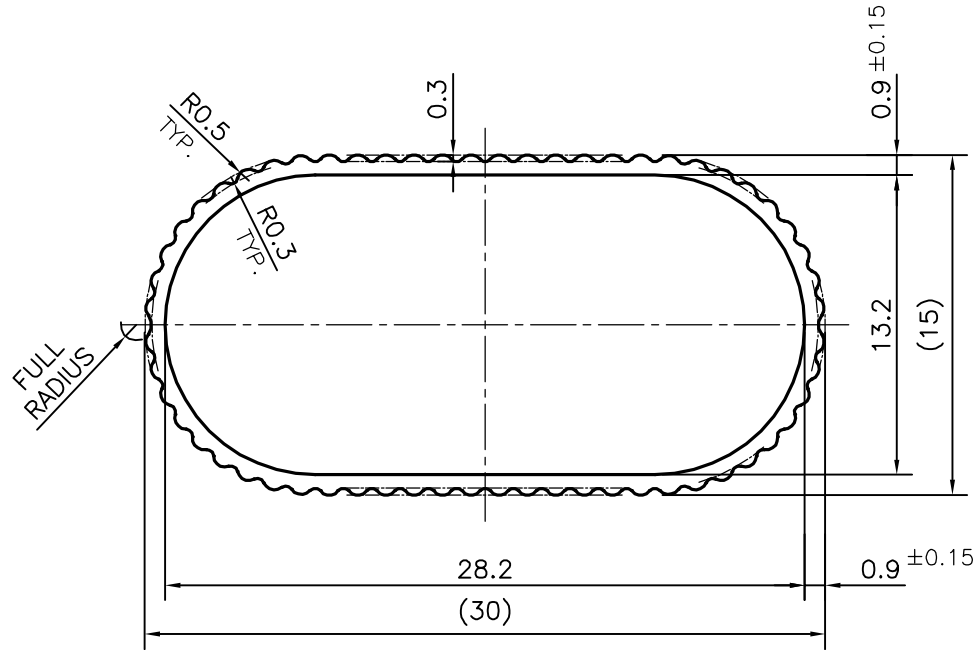

SYMBOL OF QUALITY  
AN ISO 9001 COMPANY

**JINDAL ALUMINIUM LTD.**  
BANGALORE-560073 (INDIA)

	NAME	DATE
DRAWN	PARVESH	12-12-2015
CHECKED		
APPROVED	S.S.GARG	15-12-2015
SCALE		3:1
AREA mm <sup>2</sup>		56.516
PERIMETER mm.		87.157
WEIGHT kg/m		0.153

1. ALL DIMENSIONS ARE IN mm.
2. ROUND OFF ALL SHARP CORNERS WITH 0.40 mm.
3. TOLERANCES WILL BE AS PER BS:EN-755-9 , UNLESS OTHERWISE SPECIFIED

PARTY'S NAME	MAGNAVOLT TRADING, SOUTH AFRICA	DRAWING No.	P-15430	SECTION No.	-
PARTY'S DRAWING No.	AC27132		15254		15254
ALLOY & TEMPER	6063 T6				
DESCRIPTION	OVAL TUBE-MISC.				