

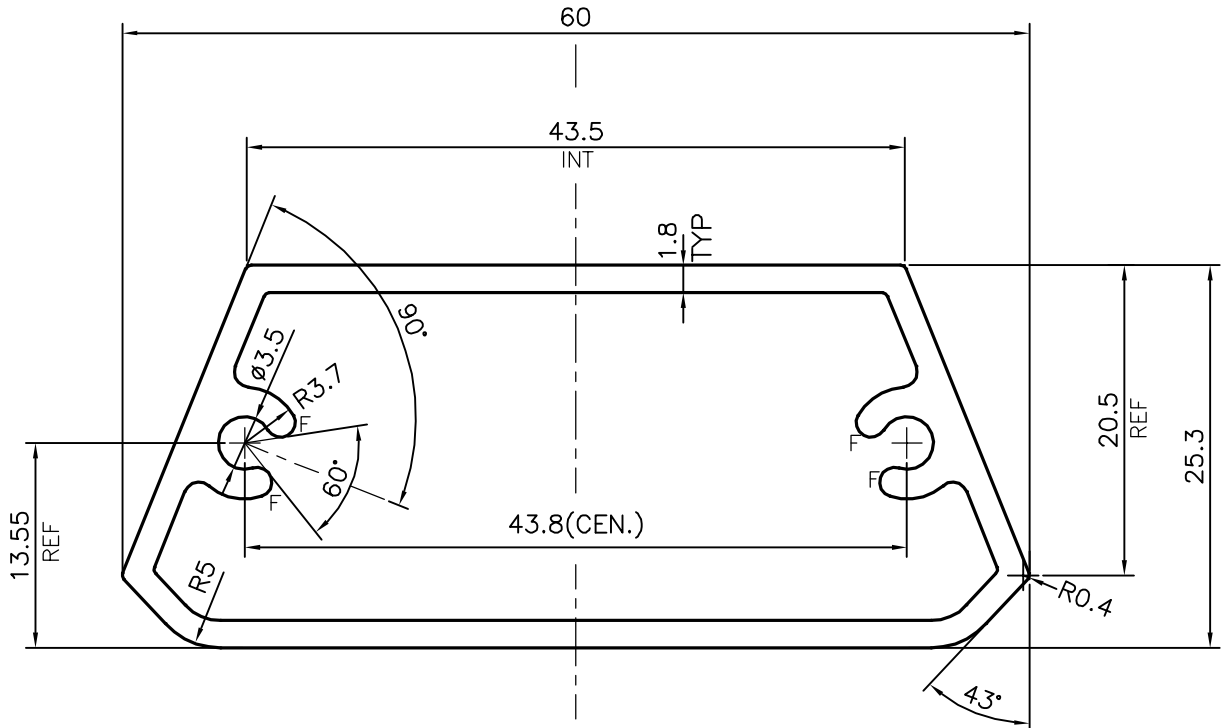

P-17952

15279

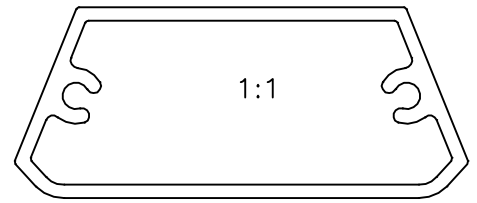

F = FULL RADIUS (4 PLACES)

 SYMBOL OF QUALITY AN ISO 9001 COMPANY	JINDAL ALUMINIUM LTD. BANGALORE-560073 (INDIA)	NAME		DATE
		DRAWN	J.P.KAUSHIK	06-03-2018
1. ALL DIMENSIONS ARE IN mm. 2. ROUND OFF ALL SHARP CORNERS WITH 0.40 mm. 3. TOLERANCES WILL BE AS PER IS:6477-1983 UNLESS OTHERWISE SPECIFIED		CHECKED		
		APPROVED		B.NATARAJA 13-03-2018
PARTY'S NAME GENERAL CATEGORY, DELHI MARKET		SCALE		2:1
		AREA mm ²		308.45
PARTY'S DRAWING No. AS PER SAMPLE		PERIMETER mm.		151.403
		WEIGHT kg/m		0.833
ALLOY & TEMPER HE9 WP		DRAWING No.		P-17952
		SECTION No.		-
DESCRIPTION MISC. SECTION		15279		15279