

P-17329

S5447

15290

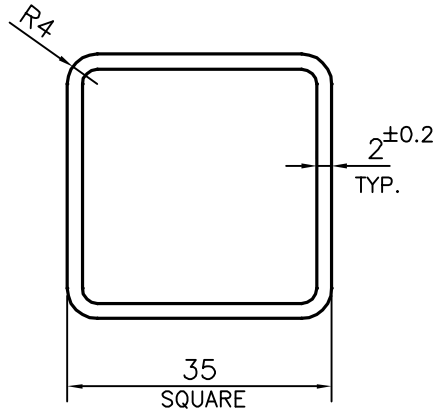

## TOLERANCES ON OVERALL WIDTHS &amp; WIDTHS ACROSS FLATS OF BARS, &amp; REGULAR SECTIONS

UPTO 6.40mm - ±0.20	UPTO 32.0mm - ±0.38	UPTO 120.0mm - ±0.85	1. STRAIGHTNESS=1.7mm/M 2. TWIST=1.7mm/M 3. ANGULARITY= ±2° 4. FLATNESS =0.007xWIDTH
UPTO 10.0mm - ±0.23	UPTO 50.0mm - ±0.46	UPTO 160.0mm - ±1.02	
UPTO 12.0mm - ±0.25	UPTO 60.0mm - ±0.53	UPTO 200.0mm - ±1.14	
UPTO 16.0mm - ±0.28	UPTO 80.0mm - ±0.69	UPTO 250.0mm - ±1.40	
UPTO 25.0mm - ±0.30	UPTO 100.0mm - ±0.75	UPTO 300.0mm - ±1.65	

 SYMBOL OF QUALITY AN ISO 9001 COMPANY	<b>JINDAL ALUMINIUM LTD.</b> <b>BANGALORE-560073 (INDIA)</b>	NAME	DATE
		DRAWN	PARVESH
		CHECKED	
		APPROVED	B.NATARAJA
			24-07-2017
1. ALL DIMENSIONS ARE IN mm. 2. ROUND OFF ALL SHARP CORNERS WITH 0.50 mm. 3. TOLERANCES WILL BE AS PER IS:6477-1983 , UNLESS OTHERWISE SPECIFIED		SCALE	1:1
		AREA mm <sup>2</sup>	253.699
		PERIMETER mm.	133.133
PARTY'S NAME	NAVRATNA INDUSTRIES, NAGPUR	WEIGHT kg/m	0.685
PARTY'S DRAWING No.	1300.01.09	DRAWING No.	SECTION No.
		P-17329	-
		S5447	S5447
		15290	15290
ALLOY & TEMPER	6063 T5 (AS PER EN573-3& EN 755-2)		
DESCRIPTION	SQUARE TUBE WITH CORNER 4mm. RADIUS		