

P-18357

S5941

15296

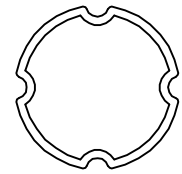

SCALE: - 1:1

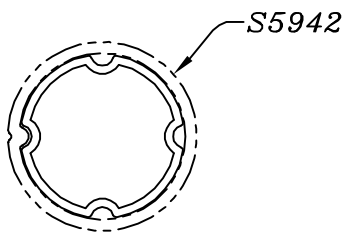
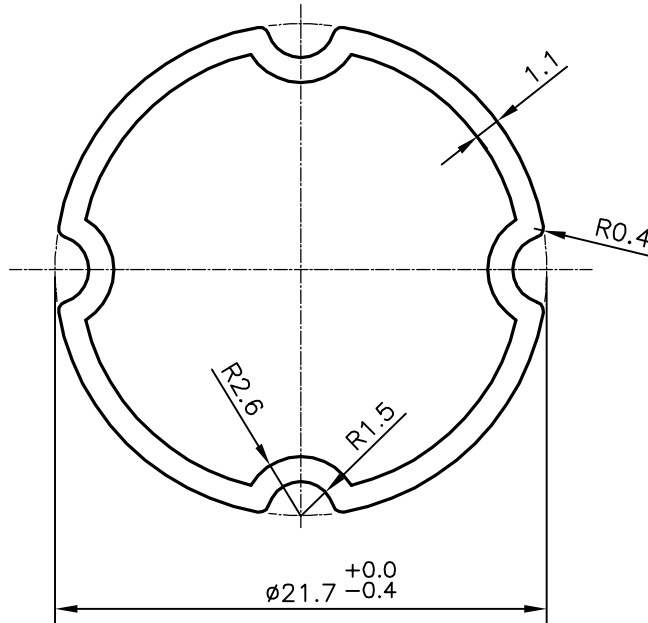

SYMBOL OF QUALITY
AN ISO 9001 COMPANY

JINDAL ALUMINIUM LTD.
BANGALORE-560073 (INDIA)

	NAME	DATE
DRAWN	PARVESH	27-07-2018
CHECKED		
APPROVED	B.NATARAJA	04-08-2018
SCALE		3:1
AREA mm ²		75.875
PERIMETER mm.		72.908
WEIGHT kg/m		0.205
DRAWING No.	SECTION No.	
P-18357	-	
S5941	S5941	
15296	15296	

1. ALL DIMENSIONS ARE IN mm. 2. ROUND OFF ALL SHARP CORNERS WITH 0.4 mm. 3. TOLERANCES WILL BE AS PER IS:6477-1983 , UNLESS OTHERWISE SPECIFIED	
PARTY'S NAME	FALCON GARDEN TOOLS PVT. LTD., LUDHIANA
PARTY'S DRAWING No.	FRD/CH/P18/001
ALLOY & TEMPER	6063 T6
DESCRIPTION	INDUSTRIAL SECTION-CUT & HOLD INNER PIPE