

P-21184

15301

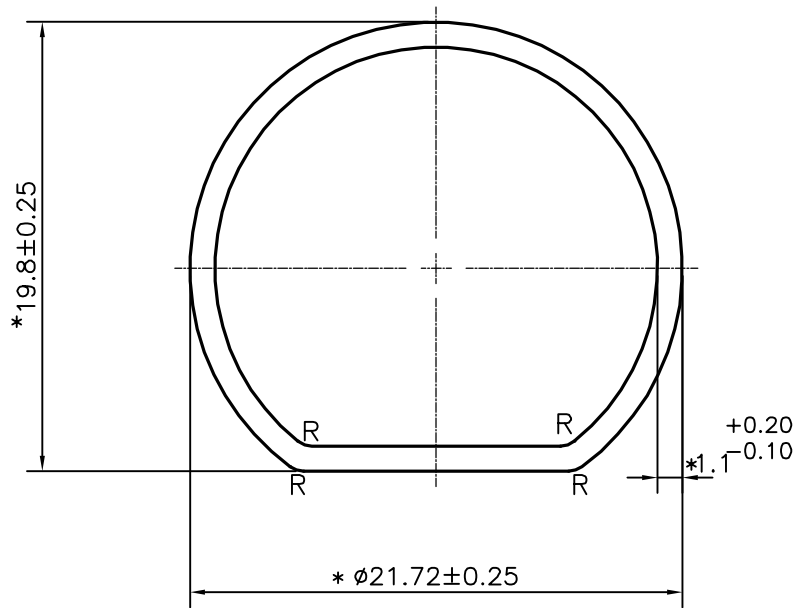
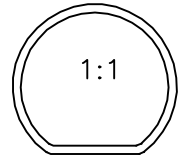

R = RADIUS 1.0 (4 PLACES)

* MARKED CRITICAL DIMENSIONS



SYMBOL OF QUALITY
AN ISO 9001 COMPANY

JINDAL ALUMINIUM LTD.
BANGALORE-560073 (INDIA)

	NAME	DATE
DRAWN	J.P.KAUSHIK	16-07-2020
CHECKED		
APPROVED	B.NATARAJA	08-08-2020
SCALE		3:1
AREA mm ²		70.377
PERIMETER mm.		67.412
WEIGHT kg/m		0.190
DRAWING No.	SECTION No.	
P-21184	-	
15301	15301	

1. ALL DIMENSIONS ARE IN mm.
2. ROUND OFF ALL SHARP CORNERS WITH 0.40 mm.
3. TOLERANCES WILL BE AS PER IS:2673-2002 , UNLESS OTHERWISE SPECIFIED

PARTY'S NAME	JAYANITA EXPORTS PVT. LTD., GREATER NOIDA
PARTY'S DRAWING No.	00503-62
ALLOY & TEMPER	6063 T5
DESCRIPTION	CURVE TUBE