

IAL-B-671

15339

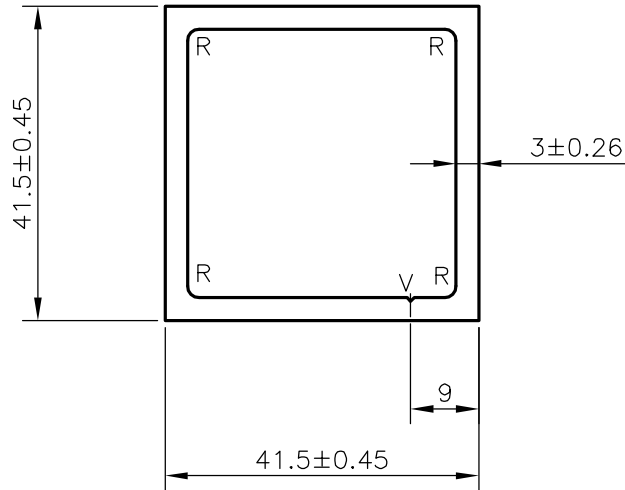

NOTE:—

$$R = 1.5R$$

$$V = 0.5 \times 1 \times 90^\circ$$



SYMBOL OF QUALITY  
AN ISO 9001 COMPANY

**JINDAL ALUMINIUM LTD.**  
BANGALORE-560073 (INDIA)

	NAME	DATE
DRAWN	S.K.SHARMA	28-03-2022
CHECKED		
APPROVED		

1. ALL DIMENSIONS ARE IN mm.
2. ROUND OFF ALL SHARP CORNERS WITH 0.40 mm.
3. TOLERANCES WILL BE AS PER BS:EN-755-9 , UNLESS OTHERWISE SPECIFIED

SCALE	1:1
AREA mm <sup>2</sup>	465.5
PERIMETER mm.	166.0
WEIGHT kg/m	1.257

PARTY'S NAME	M/S. NELCO INDIA PVT.LTD.	DRAWING No.	IAL-B-671	SECTION No.	—
PARTY'S DRAWING No.	AS PER DRAWING		15339		15339
ALLOY & TEMPER	6063-T6				
DESCRIPTION	—				