

3039

15635

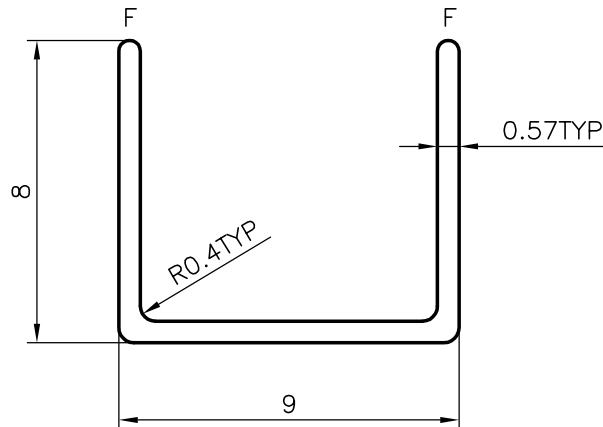

SCALE 1:1



F = FULL RADIUS (2 PLACES)



SYMBOL OF QUALITY
AN ISO 9002 COMPANY

JINDAL ALUMINIUM LTD.
BANGALORE-560073 (INDIA)

	NAME	DATE
DRAWN	RAGHAVENDRA	12-08-2004
CHECKED		
APPROVED		

1. ALL DIMENSIONS ARE IN mm.
2. ROUND OFF ALL SHARP CORNERS WITH 0.40 mm.
3. TOLERANCES WILL BE AS PER IS:3965-1981 UNLESS OTHERWISE SPECIFIED

SCALE	5:1
AREA mm ²	13.53
PERIMETER mm.	47.684
WEIGHT kg/m	0.037

PARTY'S NAME	—	DRAWING No.	3039	SECTION No.	3039
PARTY'S DRAWING No.	—		15635		15635
ALLOY & TEMPER	HE9 WP				
DESCRIPTION	CHANNEL				