

3080

15668

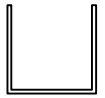

SCALE 1:1

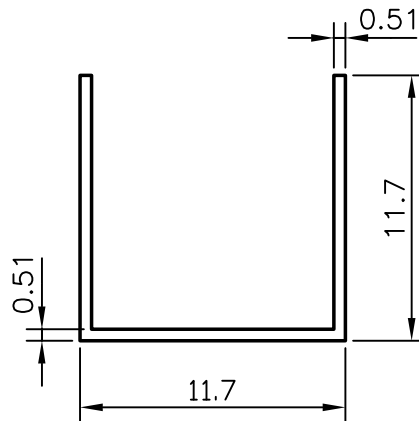

NO. OF PIECES IN 100 kgs.:— 580



SYMBOL OF QUALITY
AN ISO 9001 COMPANY

JINDAL ALUMINIUM LTD.
BANGALORE-560073 (INDIA)

	NAME	DATE
DRAWN	R.D.SHARMA	12-02-1996
CHECKED		
APPROVED		

1. ALL DIMENSIONS ARE IN mm.
2. ROUND OFF ALL SHARP CORNERS WITH 0.50 mm.
3. TOLERANCES WILL BE AS PER IS:3965-1981 UNLESS OTHERWISE SPECIFIED

SCALE	3:1
AREA mm ²	17.381
PERIMETER mm.	69.18
WEIGHT kg/m	0.047

PARTY'S NAME	—	DRAWING No.	3080	SECTION No.	3080
PARTY'S DRAWING No.	—		15668		15668
ALLOY & TEMPER	HE9 WP				
DESCRIPTION	CHANNEL				