

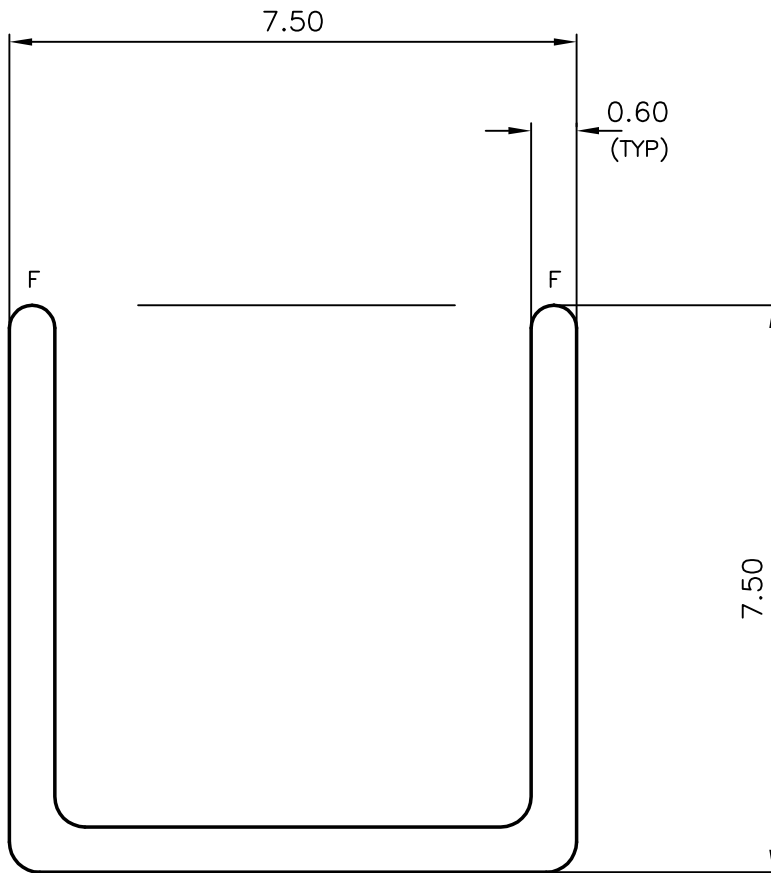

3095
15679
-



1:1



GENERAL WALL THICKNESS 0.60 mm
 F = RADII FULL (2-PLACES)

 SYMBOL OF QUALITY AN ISO 9002 COMPANY	JINDAL ALUMINIUM LTD. BANGALORE-560073 (INDIA)		NAME	DATE
		DRAWN	P,KULKARNI	5-7-2000
1. ALL DIMENSIONS ARE IN mm. 2. ROUND OFF ALL SHARP CORNERS WITH 0.40 mm. 3. TOLERANCES WILL BE AS PER B.S. 1474-1987 UNLESS OTHERWISE SPECIFIED		CHECKED		
		APPROVED		
		SCALE	10:1	
PARTY'S NAME	M/S COMARK LANKA (PVT) LTD., COLOMBO.	WEIGHT kg/m	0.034	
PARTY'S DRAWING No.	AS PER SPECIFICATION	SECTION No.	15679	
ALLOY & TEMPER	6063 T6	DRAWING No. 15679		
DESCRIPTION	CHANNEL SQ FILLET			