

P-4377-2

S1054

15718

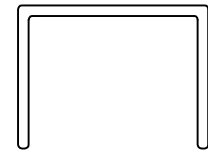

ACTUAL SIZE

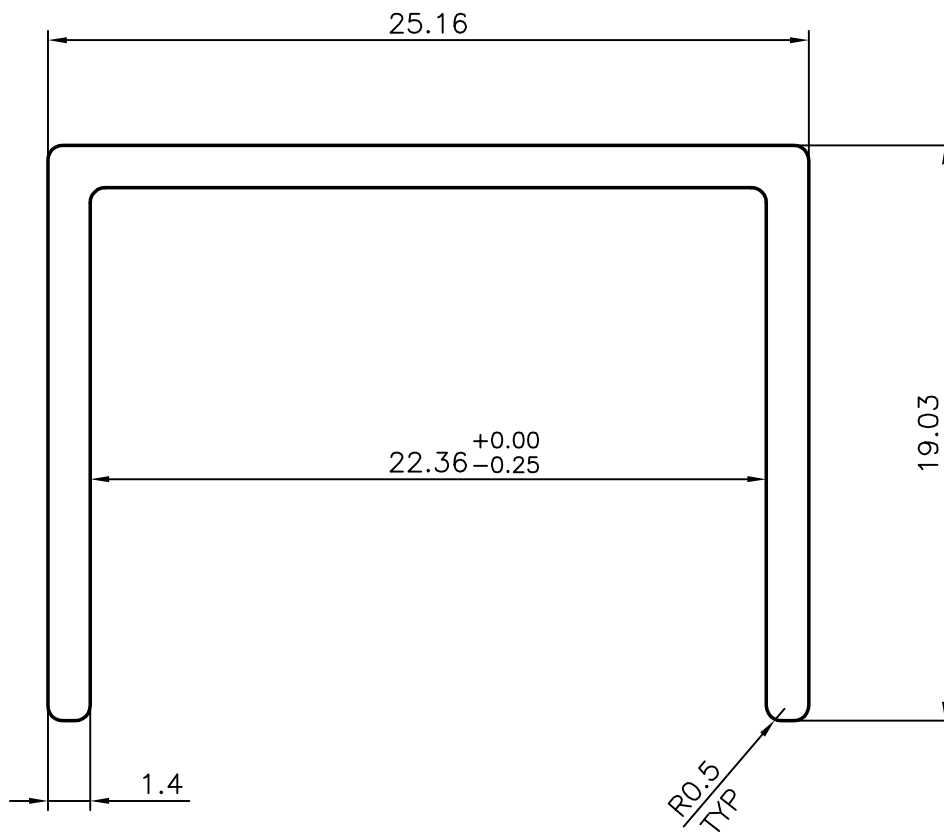

TOLERANCE GIVEN IS INDICATIVE ONLY TIGHT SLIDING FIT  
AS PER SAMPLE SHALL BE ENSURED IN THE PRODUCT



SYMBOL OF QUALITY  
AN ISO 9002 COMPANY

**JINDAL ALUMINIUM LTD.**  
BANGALORE-560073 (INDIA)

	NAME	DATE
DRAWN	malingappa	20.09.2003
CHECKED		
APPROVED		
SCALE		4:1
AREA mm <sup>2</sup>		84.5
PERIMETER mm.		122
WEIGHT kg/m		0.228
DRAWING No.	SECTION No.	
P-4377-2	-	
S1054	S1054	
15718	15718	

1. ALL DIMENSIONS ARE IN mm.
2. ROUND OFF ALL SHARP CORNERS WITH 0.40 mm.
3. TOLERANCES WILL BE AS PER IS: 3965-1981 UNLESS OTHERWISE SPECIFIED

PARTY'S NAME	ELECTRONIC CONTROLS & DISCHARGE SYST. PVT. LTD., KOCHI
PARTY'S DRAWING No.	ECF-01-025-3 2/3
ALLOY & TEMPER	6063 T6
DESCRIPTION	LB-10-0-0-S-S-1