

P-15293

15776

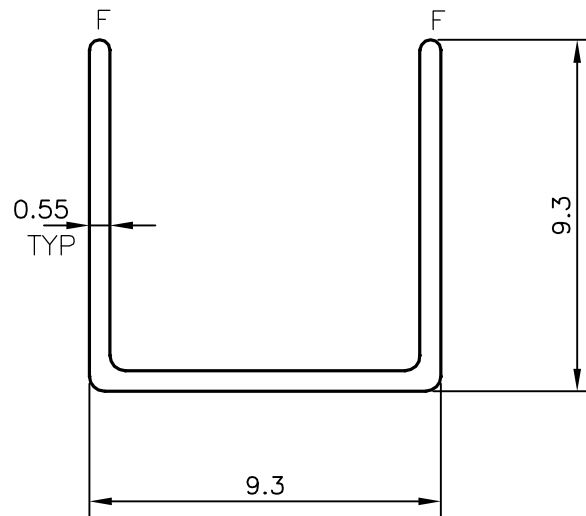

1:1



F = FULL RADIUS (2 PLACES)



SYMBOL OF QUALITY
AN ISO 9001 COMPANY

JINDAL ALUMINIUM LTD.
BANGALORE-560073 (INDIA)

	NAME	DATE
DRAWN	J.P.KAUSHIK	06-11-2015
CHECKED		
APPROVED	S.S.GARG	13-11-2015
SCALE		5:1
AREA mm ²		14.675
PERIMETER mm.		53.541
WEIGHT kg/m		0.040
DRAWING No.	SECTION No.	
P-15293	-	
15776	15776	

1. ALL DIMENSIONS ARE IN mm.
2. ROUND OFF ALL SHARP CORNERS WITH 0.40 mm.
3. TOLERANCES WILL BE AS PER BS:EN-755-9 , UNLESS OTHERWISE SPECIFIED

PARTY'S NAME	LANKA ALUMINIUM INDUSTRIES PLC, SRI LANKA
PARTY'S DRAWING No.	AS PER DRAWING
ALLOY & TEMPER	6063 T6
DESCRIPTION	CHANNEL