

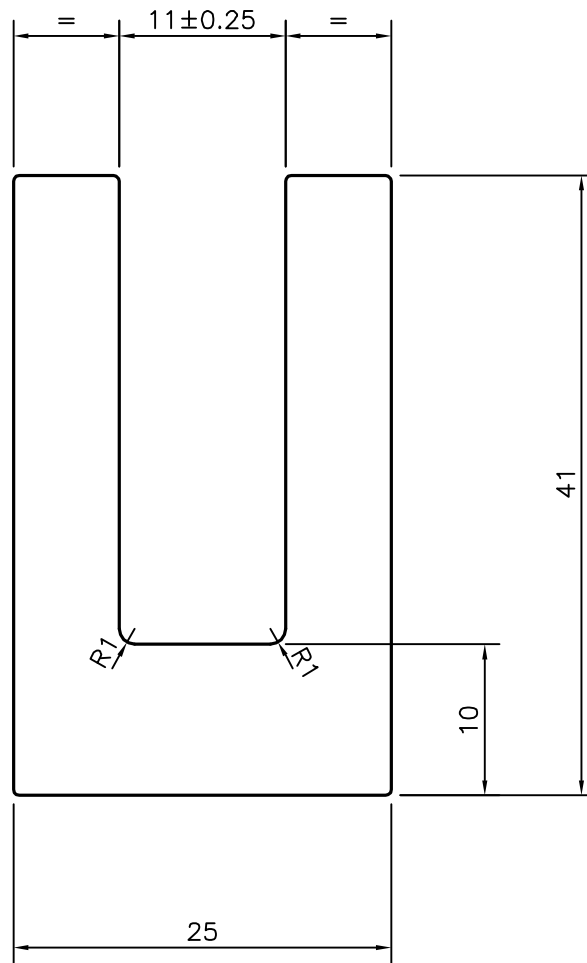

P-17208-1
S5417
15793

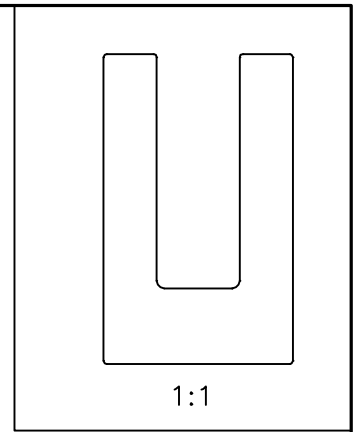

TOLERANCES ON OVERALL WIDTHS & WIDTHS ACROSS FLATS OF BARS, & REGULAR SECTIONS

UPTO 6.40mm - ±0.20	UPTO 32.0mm - ±0.38	UPTO 120.0mm - ±0.85	UPTO 320.00mm - ±1.70
UPTO 10.0mm - ±0.23	UPTO 50.0mm - ±0.46	UPTO 160.0mm - ±1.02	
UPTO 12.0mm - ±0.25	UPTO 60.0mm - ±0.53	UPTO 200.0mm - ±1.14	
UPTO 16.0mm - ±0.28	UPTO 80.0mm - ±0.69	UPTO 250.0mm - ±1.40	
UPTO 25.0mm - ±0.30	UPTO 100.0mm - ±0.75	UPTO 300.0mm - ±1.65	

 SYMBOL OF QUALITY AN ISO 9001 COMPANY	JINDAL ALUMINIUM LTD. BANGALORE-560073 (INDIA)	DRAWN	J.P.KAUSHIK	DATE	06-06-2017
		CHECKED			
1. ALL DIMENSIONS ARE IN mm. 2. ROUND OFF ALL SHARP CORNERS WITH 0.40 mm. 3. TOLERANCES WILL BE AS PER IS:3965-1981 UNLESS OTHERWISE SPECIFIED		APPROVED	B.NATARAJA		10-06-2017
		SCALE			2:1
PARTY'S NAME VIJAYA TOOLS AND COMPONENTS, BANGALORE		AREA	mm ²		684.223
		PERIMETER	mm.		192.112
PARTY'S DRAWING No. VTC-010 REV. 01		WEIGHT	kg/m		1.847
		DRAWING No.		SECTION No.	
ALLOY & TEMPER 6061 T6		P-17208-1			-
		S5417			S5417
DESCRIPTION CHANNEL		15793			15793