

P-9815

S2494

16026

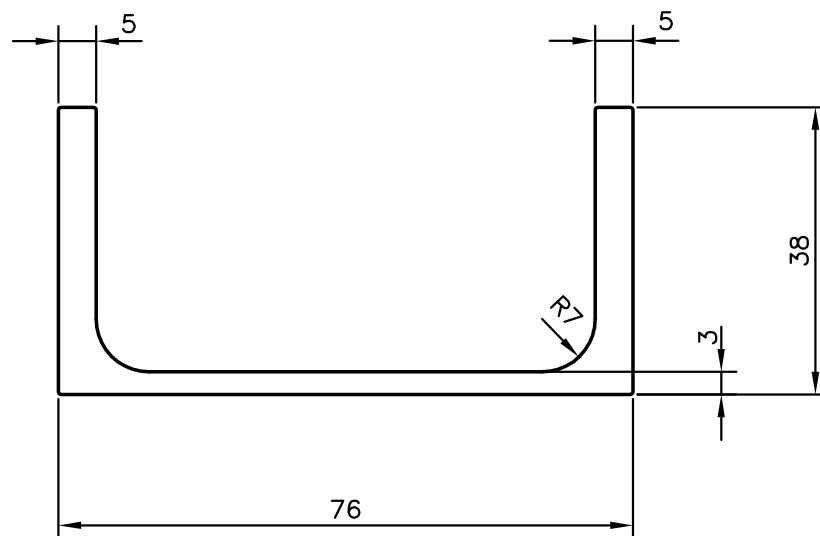

SYMBOL OF QUALITY
AN ISO 9001 COMPANY

JINDAL ALUMINIUM LTD.
BANGALORE-560073 (INDIA)

| | NAME | DATE |
|----------------------|-------------|------------|
| DRAWN | J.P.KAUSHIK | 15-02-2010 |
| CHECKED | | |
| APPROVED | S.S.GARG | 19-03-2010 |
| SCALE | | 1:1 |
| AREA mm ² | | 598.825 |
| PERIMETER mm. | | 290.961 |
| WEIGHT kg/m | | 1.617 |
| DRAWING No. | SECTION No. | |
| P-9815 | - | |
| S2494 | S2494 | |
| 16026 | 16026 | |
| | | |
| | | |

1. ALL DIMENSIONS ARE IN mm.
2. ROUND OFF ALL SHARP CORNERS WITH 0.40 mm.
3. TOLERANCES WILL BE AS PER IS:3965-1981, UNLESS OTHERWISE SPECIFIED

| | |
|---------------------|--|
| PARTY'S NAME | CONSTRUCTION SPECIALITIES INTERNATIONAL INDIA PVT. LTD., MUMBAI |
| PARTY'S DRAWING No. | CS-JOBNAME-00X |
| ALLOY & TEMPER | 6063 T6 |
| DESCRIPTION | CHANNEL WITH RADIUS |