

P-10901
S2896
16029

EXPOSED SURFACE

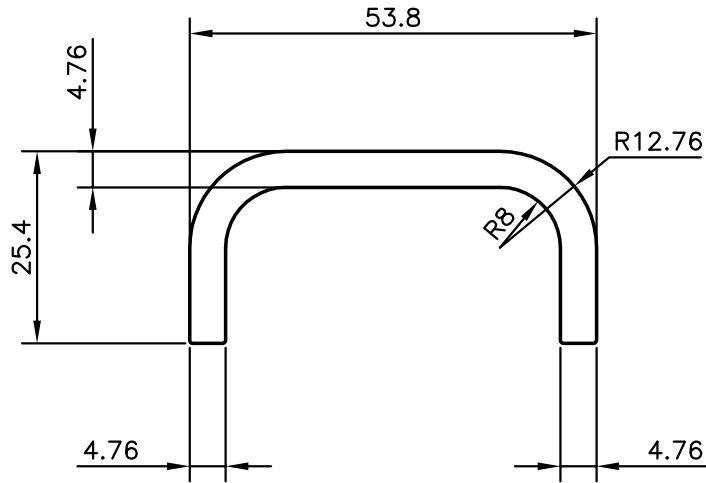
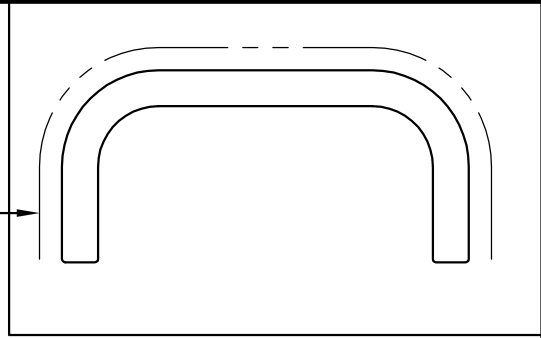

SYMBOL OF QUALITY
AN ISO 9001 COMPANY

JINDAL ALUMINIUM LTD.
BANGALORE-560073 (INDIA)

	NAME	DATE
DRAWN	J.P.KAUSHIK	23-04-2011
CHECKED		
APPROVED	S.S.GARG	26-04-2011

1. ALL DIMENSIONS ARE IN mm.
2. ROUND OFF ALL SHARP CORNERS WITH 0.40 mm.
3. TOLERANCES WILL BE AS PER IS:3965-1981 UNLESS OTHERWISE SPECIFIED

SCALE	1:1
AREA mm ²	410.031
PERIMETER mm.	181.173
WEIGHT kg/m	1.107

PARTY'S NAME	AMBA INDUSTRIES, BANGALORE	DRAWING No.	P-10901	SECTION No.	-
PARTY'S DRAWING No.	JBTC-002		S2896		S2896
ALLOY & TEMPER	6061 T6		16029		16029
DESCRIPTION	CHANNEL-MISC.				