

P-8596
16310
X1027
16310

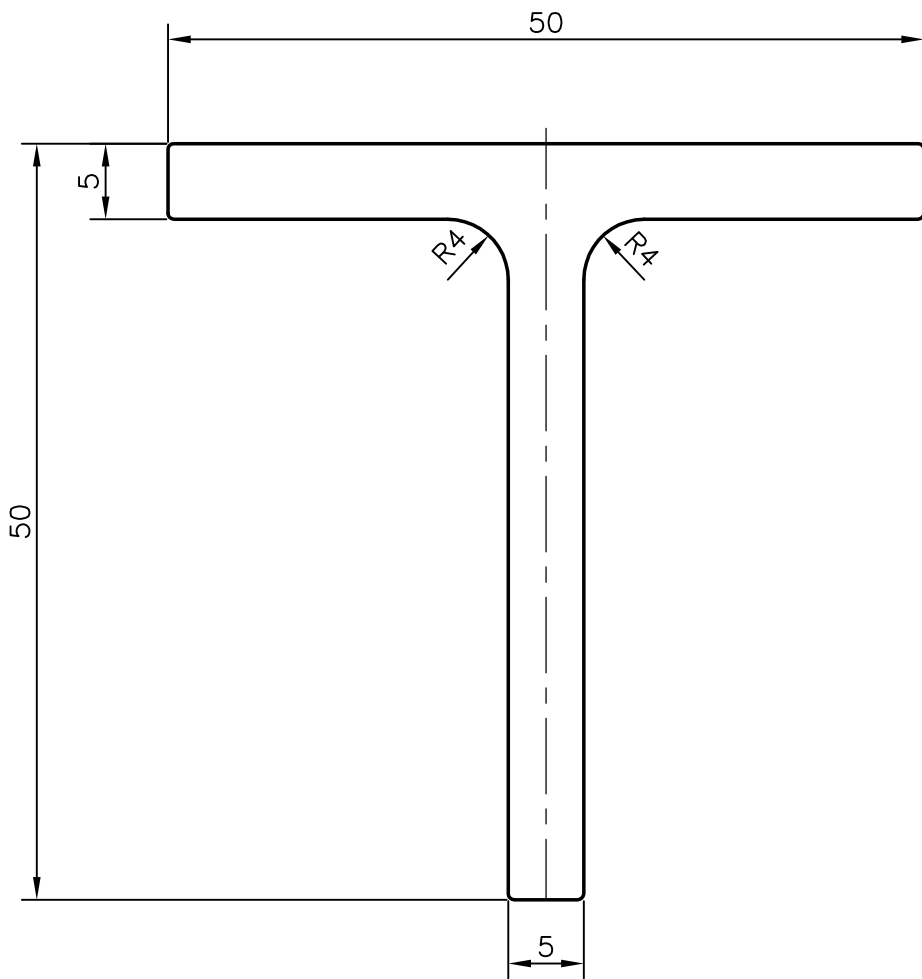
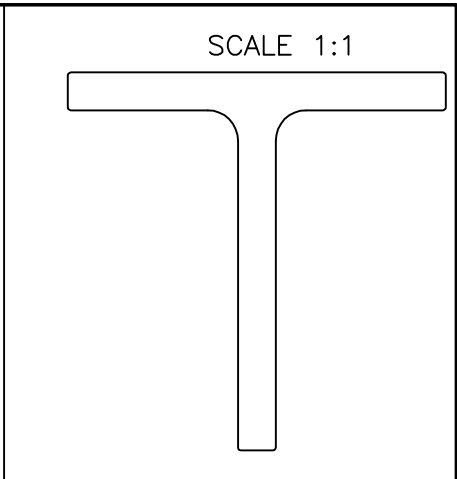

JINDAL ALUMINIUM LTD.
BANGALORE-560073 (INDIA)

	NAME	DATE
DRAWN	ABHARANI	28-08-2008
CHECKED		
APPROVED		

1. ALL DIMENSIONS ARE IN mm.
2. ROUND OFF ALL SHARP CORNERS WITH 0.40 mm.
3. TOLERANCES WILL BE AS PER BS:EN-755 UNLESS OTHERWISE SPECIFIED

SCALE	2:1
AREA mm ²	481.661
PERIMETER mm.	195.54
WEIGHT kg/m	1.300

PARTY'S NAME	SEASPRAY, DUBAI
PARTY'S DRAWING No.	EXT-T002-1-A
ALLOY & TEMPER	6082 T6
DESCRIPTION	T-ROUND FILLET TOES

DRAWING No.	SECTION No.
P-8596	-
16310	16310
X1027	X1027
16310	16310