

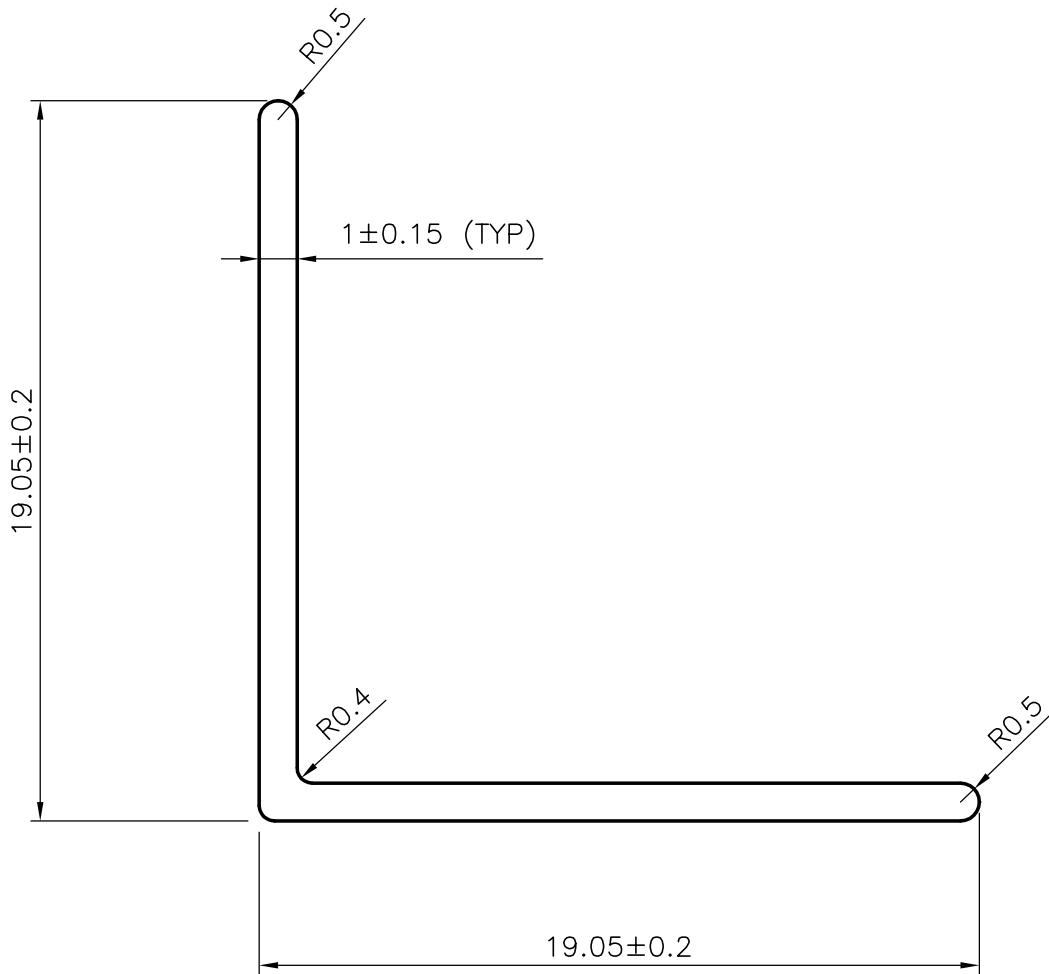

S677  
3466  
16462

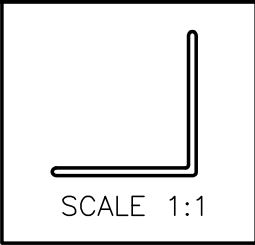

 SYMBOL OF QUALITY AN ISO 9002 COMPANY	<b>JINDAL ALUMINIUM LTD.</b> BANGALORE-560073 (INDIA)		NAME	DATE
		DRAWN	RAGHAVENDRA	03-05-01
1. ALL DIMENSIONS ARE IN mm. 2. ROUND OFF ALL SHARP CORNERS WITH 0.40 mm. 3. TOLERANCES WILL BE AS PER I S 3965-1981 UNLESS OTHERWISE SPECIFIED		CHECKED		
		APPROVED		
		SCALE	5:1 , 1:1	
PARTY'S NAME	MANJUL ENTERPRISES., MUMBAI	WEIGHT kg/m	0.099	
PARTY'S DRAWING No.	AS PER SPECIFICATION	SECTION No.	16462	
ALLOY & TEMPER	HE9WP	DRAWING No. 16462		
DESCRIPTION	EQUAL ANGLE			