

P-4681

3481

16477

SCALE 1:1

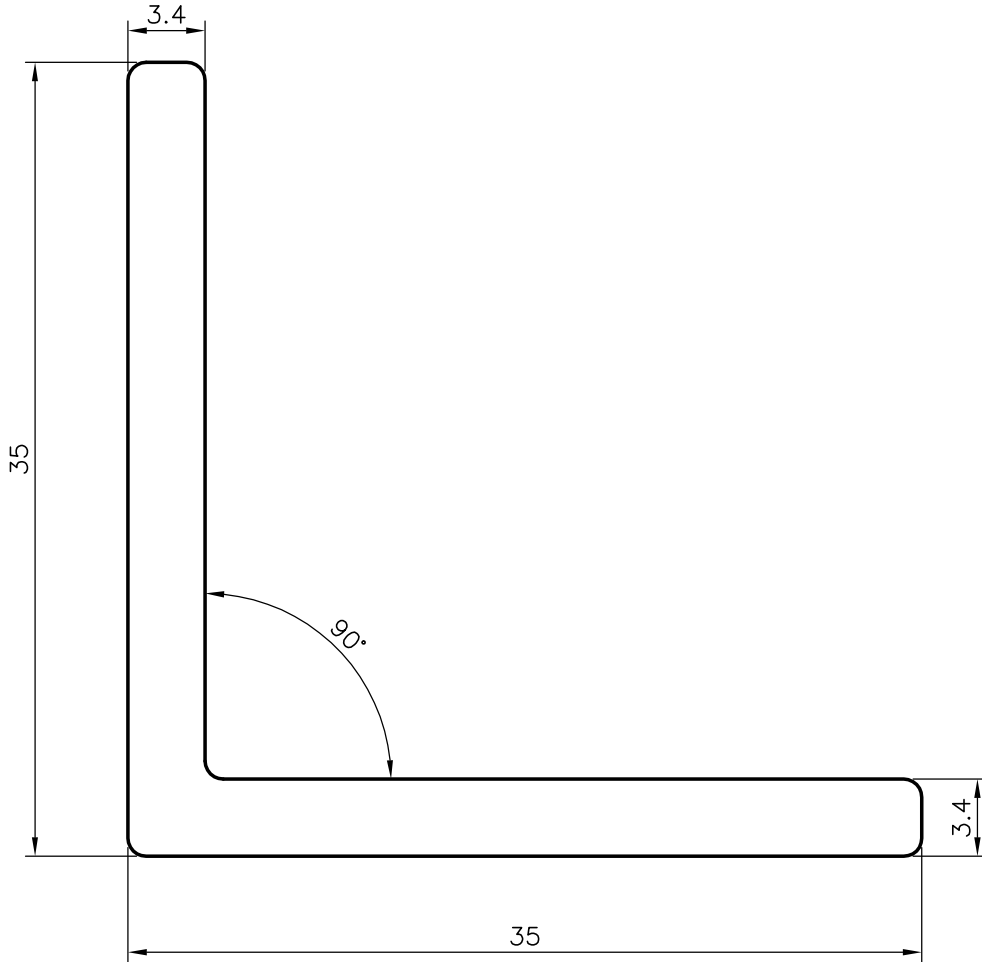

SYMBOL OF QUALITY  
AN ISO 9002 COMPANY

**JINDAL ALUMINIUM LTD.**  
BANGALORE-560073 (INDIA)

	NAME	DATE
DRAWN	RAGHAVENDRA	30-01-2004
CHECKED		
APPROVED		

1. ALL DIMENSIONS ARE IN mm.
2. ROUND OFF ALL SHARP CORNERS WITH 0.40 mm.
3. TOLERANCES WILL BE AS PER BS:1474-1987 UNLESS OTHERWISE SPECIFIED

SCALE	3:1
AREA mm <sup>2</sup>	225.891
PERIMETER mm.	137.94
WEIGHT kg/m	0.610

PARTY'S NAME	SYDNEY ALUMINIUM & GLASS DOHA
PARTY'S DRAWING No.	AS PER SAMPLE
ALLOY & TEMPER	6063 T6
DESCRIPTION	EQUAL ANGLE

DRAWING No.	SECTION No.
P-4681	-
3481	3481
16477	16477