

P-11492-1

S3241

16783

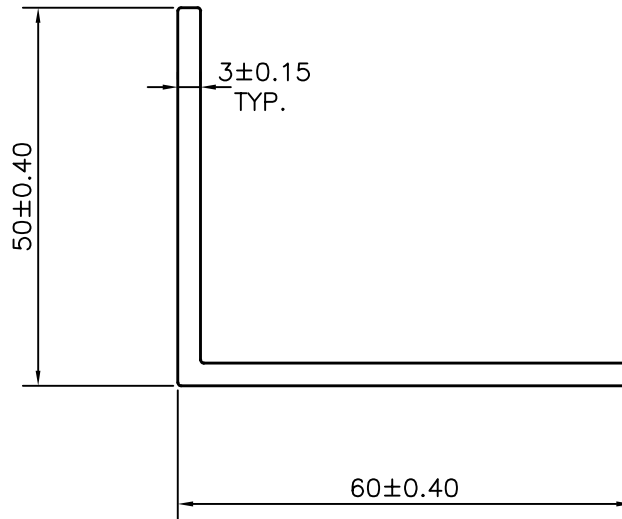

SYMBOL OF QUALITY
AN ISO 9001 COMPANY

JINDAL ALUMINIUM LTD.
BANGALORE-560073 (INDIA)

	NAME	DATE
DRAWN	PARVESH	01-03-2012
CHECKED		
APPROVED	S.S.GARG	02-04-2012
SCALE		1:1
AREA mm ²		320.863
PERIMETER mm.		218.97
WEIGHT kg/m		0.866
DRAWING No.	SECTION No.	
P-11492-1	-	
S3241	S3241	
16783	16783	

1. ALL DIMENSIONS ARE IN mm.
2. ROUND OFF ALL SHARP CORNERS WITH 0.40 mm.
3. TOLERANCES WILL BE AS PER DIN EN-12020-2, UNLESS OTHERWISE SPECIFIED

PARTY'S NAME	SPACEBIZ SOLUTIONS PVT. LTD., BANGALORE
PARTY'S DRAWING No.	AS PER SAMPLE
ALLOY & TEMPER	HE9 WP
DESCRIPTION	UNEQUAL ANGLE