

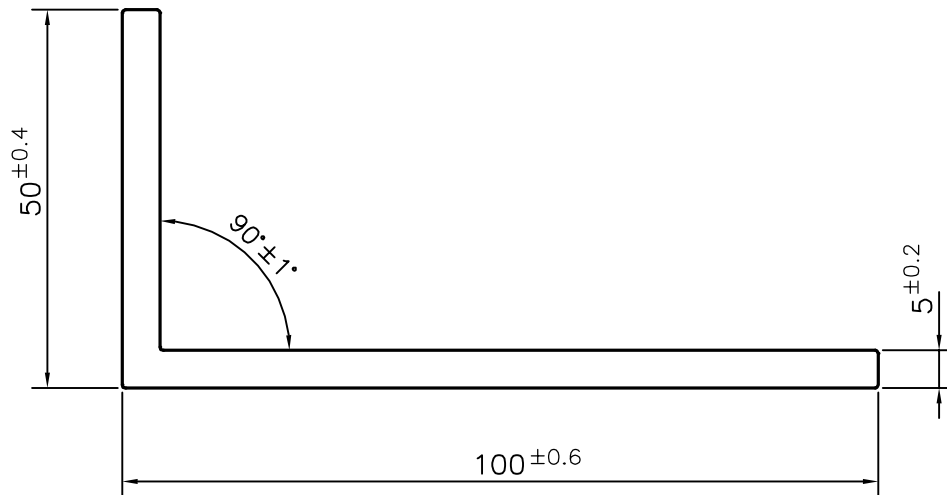



P-14616

S4453

16791



-  STRAIGHTNESS (BEND / TWIST) 1 MM MAX. OVER 2700MM LENGTH
 FLATNESS 1 mm. MAX. ON WIDTH
 ANGLE 90° \pm 1°.
 AS PER CUSTOMER REQUIREMENT ON DATE 30-06-2015.

TOLERANCES ON OVERALL WIDTHS & WIDTHS ACROSS FLATS OF BARS, & REGULAR SECTIONS

| | | |
|--------------------------|---------------------------|---------------------------|
| UPTO 6.40mm - \pm 0.20 | UPTO 32.0mm - \pm 0.38 | UPTO 120.0mm - \pm 0.85 |
| UPTO 10.0mm - \pm 0.23 | UPTO 50.0mm - \pm 0.46 | UPTO 160.0mm - \pm 1.02 |
| UPTO 12.0mm - \pm 0.25 | UPTO 60.0mm - \pm 0.53 | UPTO 200.0mm - \pm 1.14 |
| UPTO 16.0mm - \pm 0.28 | UPTO 80.0mm - \pm 0.69 | UPTO 250.0mm - \pm 1.40 |
| UPTO 25.0mm - \pm 0.30 | UPTO 100.0mm - \pm 0.75 | UPTO 300.0mm - \pm 1.65 |

| | | | | |
|---|---|----------------------|----------------|-------------|
|  SYMBOL OF QUALITY AN ISO 9001 COMPANY | JINDAL ALUMINIUM LTD. BANGALORE-560073 (INDIA) | DRAWN | NAME | DATE |
| | | CHECKED | PARVESH | 06-05-2015 |
| 1. ALL DIMENSIONS ARE IN mm. 2. ROUND OFF ALL SHARP CORNERS WITH 0.40 mm. 3. TOLERANCES WILL BE AS PER IS:3965-1981, UNLESS OTHERWISE SPECIFIED | | APPROVED | S.S.GARG | 08-05-2015 |
| | | SCALE | | 1:1 |
| PARTY'S NAME AGUERRI INDUSTRIES PVT. LTD., CHENNAI | | AREA mm ² | | 724.863 |
| | | PERIMETER mm. | | 298.97 |
| PARTY'S DRAWING No. 04642 | | WEIGHT kg/m | | 1.957 |
| | | DRAWING No. | | SECTION No. |
| ALLOY & TEMPER 6063 T5 | | P-14616 | | - |
| | | S4453 | | S4453 |
| DESCRIPTION UNEQUAL ANGLE | | 16791 | | 16791 |
| | | | | |