

3756

17206

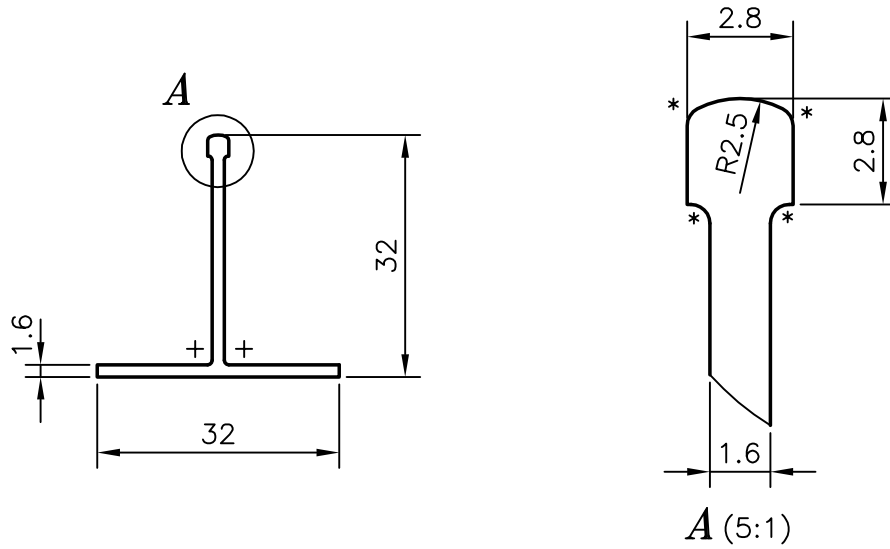

\* = 0.50 RADIUS (4)

+ = 0.60 RADIUS (2)

**JINDAL ALUMINIUM LTD.****BANGALORE-560073**

NAME

DATE

DRAWN

R.D.Sharma

13-04-98

CHECKED

APPROVED

1. ALL DIMENSIONS ARE IN mm.
2. ROUND OFF ALL SHARP CORNERS WITH 0.4 mm.
3. TOLERANCES WILL BE AS PER IS: 3965-1981 ,UNLESS OTHERWISE SPECIFIED

PARTY'S NAME

INDIAN ASPHALTS PVT. LTD., MADRAS

SCALE

1:1 &amp; 5:1

PARTY'S DRAWING No.

NIL

WEIGHT kg/m

0.278

ALLOY &amp; TEMPER

HE9 WP

SECTION No.

17206

LENGTH

3658 mm.

DRAWING No.

DESCRIPTION

BULBED TEE

17206