

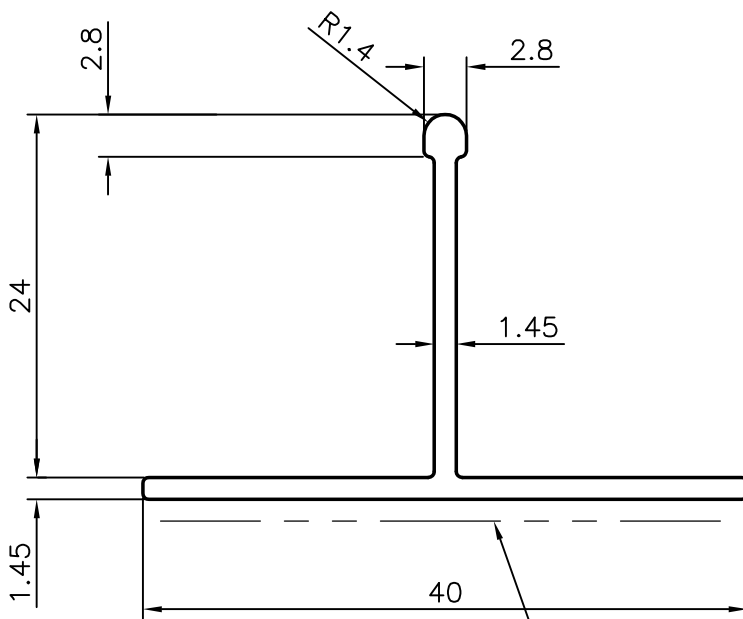

P-4697
S1151
17218

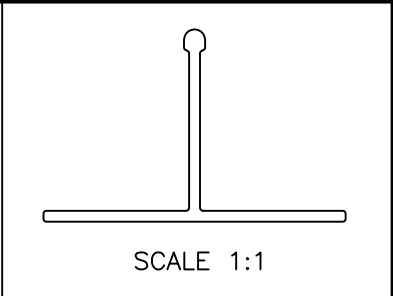

EXPOSED SURFACE  
BETTER FINISH REQUIRED

 SYMBOL OF QUALITY AN ISO 9002 COMPANY	<b>JINDAL ALUMINIUM LTD.</b> BANGALORE-560073 (INDIA)	NAME		DATE
		DRAWN	MALINGAPPA	02-02-2004
1. ALL DIMENSIONS ARE IN mm. 2. ROUND OFF ALL SHARP CORNERS WITH 0.40 mm. 3. TOLERANCES WILL BE AS PER IS:3965-1981 UNLESS OTHERWISE SPECIFIED		CHECKED		
		APPROVED		
PARTY'S NAME THE STAR ALUMINIUM WORKS, MYSORE		SCALE		2:1
		AREA mm <sup>2</sup>		95.67
PARTY'S DRAWING No. AS PER SKETCH		PERIMETER mm.		130.7
		WEIGHT kg/m		0.258
ALLOY & TEMPER HE9WP		DRAWING No.		SECTION No.
		P-4697		-
DESCRIPTION BULB HEAD TEE SECTION		S1151		S1151
		17218		17218