

P-11392-1

S3127

17221

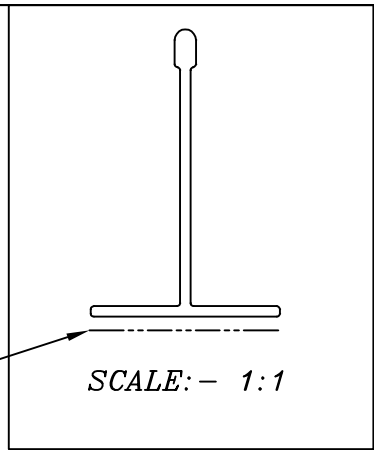

EXPOSED SURFACE

SCALE: - 1:1

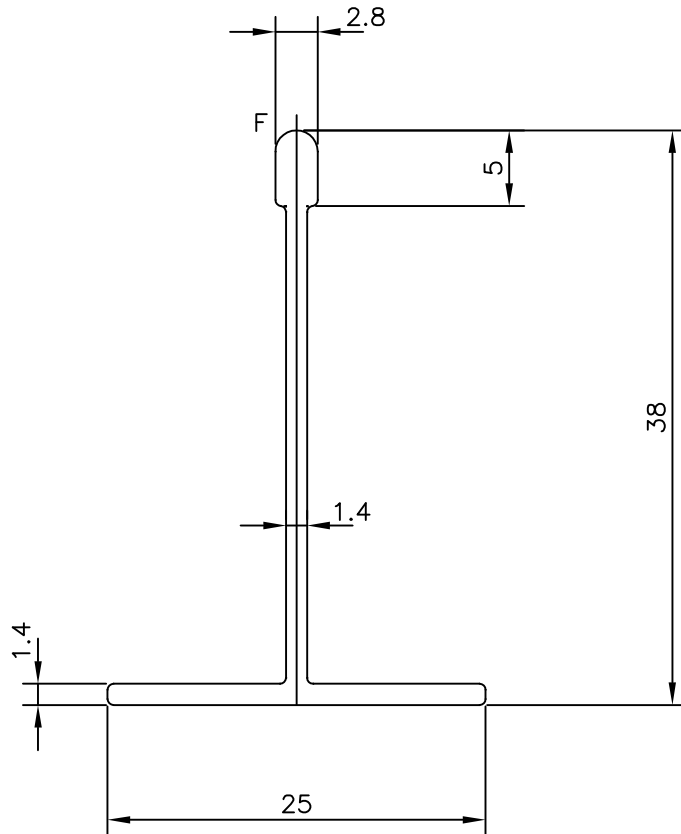

F = FULL RADIUS (1 PLACE)



SYMBOL OF QUALITY  
AN ISO 9001 COMPANY

**JINDAL ALUMINIUM LTD.**  
BANGALORE-560073 (INDIA)

	NAME	DATE
DRAWN	PARVESH	15-12-2011
CHECKED		
APPROVED	S.S.GARG	16-12-2011
SCALE		2:1
AREA	mm <sup>2</sup>	92.33
PERIMETER	mm.	125.893
WEIGHT	kg/m	0.249
DRAWING No.	SECTION No.	
P-11392-1	-	
S3127	S3127	
17221	17221	

1. ALL DIMENSIONS ARE IN mm.
2. ROUND OFF ALL SHARP CORNERS WITH 0.40 mm.
3. TOLERANCES WILL BE AS PER IS:3965-1981 , UNLESS OTHERWISE SPECIFIED

PARTY'S NAME	THE STAR ALUMINIUM WORKS, MYSORE
PARTY'S DRAWING No.	SAW/2011-2012/288
ALLOY & TEMPER	HE9 WP
DESCRIPTION	BULBED TEE-STRAIGHT HEAD