

P-14070

17222

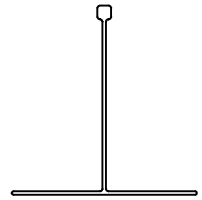

SCALE: - 1:1

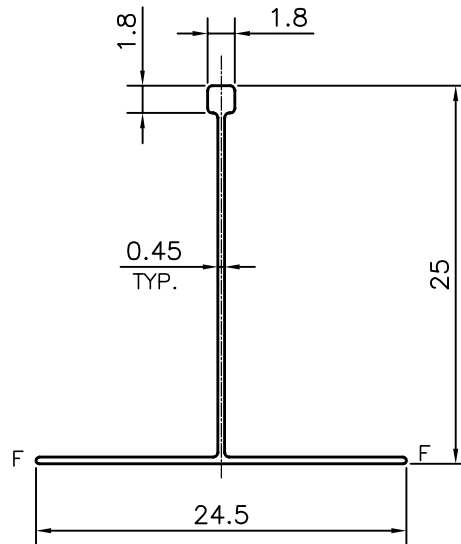

AVERAGE WEIGHT PER PIECE 3658 mm. LONG - 0.240 kg/m

F = FULL RADIUS (2 PLACES)

TOLERANCES ON OVERALL WIDTHS & WIDTHS ACROSS FLATS OF BARS, & REGULAR SECTIONS

UPTO 6.40mm - ±0.20	UPTO 32.0mm - ±0.38	UPTO 120.0mm - ±0.85	1. STRAIGHTNESS=1.7mm/M 2. TWIST=1.7mm/M 3. ANGULARITY= ±2° 4. FLATNESS =0.007xWIDTH
UPTO 10.0mm - ±0.23	UPTO 50.0mm - ±0.46	UPTO 160.0mm - ±1.02	
UPTO 12.0mm - ±0.25	UPTO 60.0mm - ±0.53	UPTO 200.0mm - ±1.14	
UPTO 16.0mm - ±0.28	UPTO 80.0mm - ±0.69	UPTO 250.0mm - ±1.40	
UPTO 25.0mm - ±0.30	UPTO 100.0mm - ±0.75	UPTO 300.0mm - ±1.65	



SYMBOL OF QUALITY
AN ISO 9001 COMPANY

JINDAL ALUMINIUM LTD.
BANGALORE-560073 (INDIA)

	NAME	DATE
DRAWN	PARVESH	28-10-2014
CHECKED		
APPROVED	S.S.GARG	05-11-2014

- ALL DIMENSIONS ARE IN mm.
- ROUND OFF ALL SHARP CORNERS WITH 0.40 mm.
- TOLERANCES WILL BE AS PER IS:3965-1981, UNLESS OTHERWISE SPECIFIED

SCALE	2:1
AREA mm ²	24.459
PERIMETER mm.	100.284
WEIGHT kg/m	0.066

PARTY'S NAME	GENERAL CATEGORY, HYDERABAD MARKET	DRAWING No.	P-14070	SECTION No.	-
PARTY'S DRAWING No.	LIGHTER OF SECTION No. 17209		17222		17222
ALLOY & TEMPER	HE9 WP				
DESCRIPTION	BULBED TEES - STRAIGHT HEAD				