

P-21623

17461

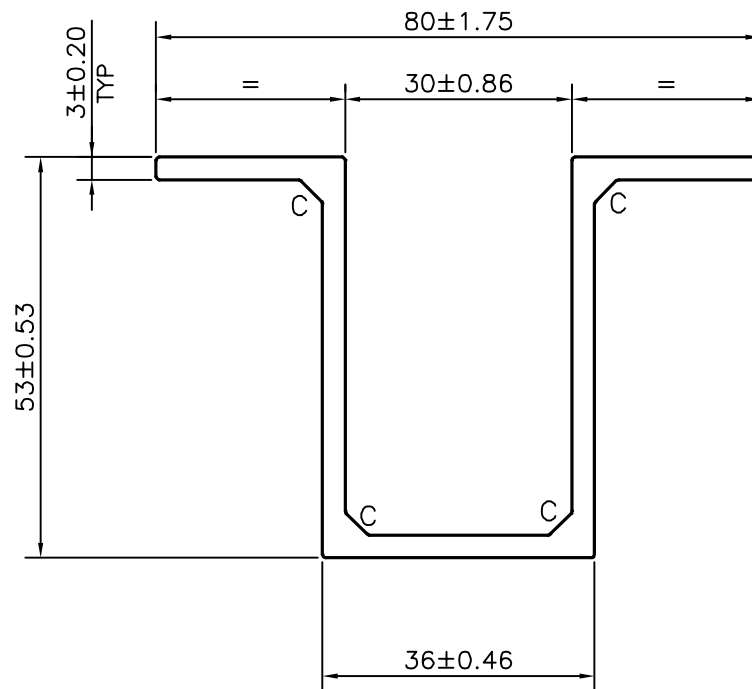

AVERAGE WEIGHT: -1.356 kg/m TO 1.656 kg/m

C = CHAMFER 3x45° (4 PLACES)



SYMBOL OF QUALITY  
AN ISO 9001 COMPANY

**JINDAL ALUMINIUM LTD.**  
BANGALORE-560073 (INDIA)

	NAME	DATE
DRAWN	J.P.KAUSHIK	05-10-2020
CHECKED		
APPROVED	B.NATARAJA	12-10-2020

1. ALL DIMENSIONS ARE IN mm.
2. ROUND OFF ALL SHARP CORNERS WITH 0.40 mm.
3. TOLERANCES WILL BE AS PER, IS:3965-1981 UNLESS OTHERWISE SPECIFIED

SCALE	1:1
AREA mm <sup>2</sup>	557.753
PERIMETER mm.	357.459
WEIGHT kg/m	1.506

PARTY'S NAME	SUNTROP SOLAR PVT. LTD., BANGALORE	DRAWING No.	P-21623	SECTION No.	-
PARTY'S DRAWING No.	AS PER DRAWING		17461		17461
ALLOY & TEMPER	6063 T6				
DESCRIPTION	MISC. CHANNEL				