

P-0848
3899
17533

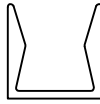

1:1

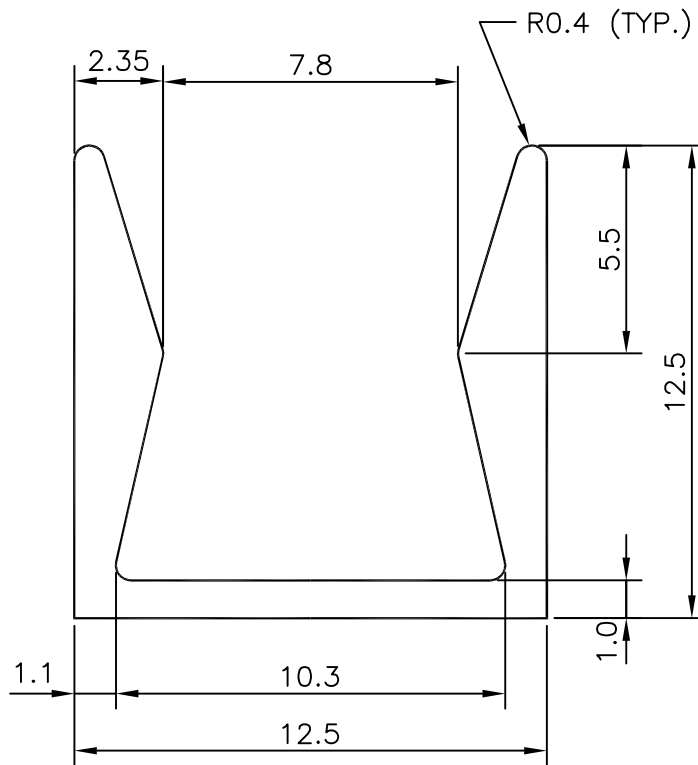

NO. OF PIECES REQUIRED:-200-208/100kgs

JINDAL ALUMINIUM LTD.
BANGALORE-560073

		NAME	DATE
		DRAWN	R.D.Sharma 28-11-95
1. ALL DIMENSIONS ARE IN mm. 2. ROUND OFF ALL SHARP CORNERS WITH 0.4 mm. 3. TOLERANCES WILL BE AS PER IS: 3965-1981 ,UNLESS OTHERWISE SPECIFIED		CHECKED	
		APPROVED	
PARTY'S NAME	GENERAL CATEGORY	SCALE	1:1 & 5:1
PARTY'S DRAWING No.	-	WEIGHT kg/m	0.133
ALLOY & TEMPER	HE9 WP	SECTION No.	17533
LENGTH	3658 mm.	DRAWING No.	17533
DESCRIPTION	CLIPPING CHANNEL		