

3926

17545

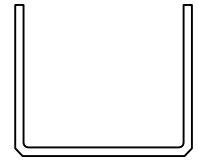

1:1

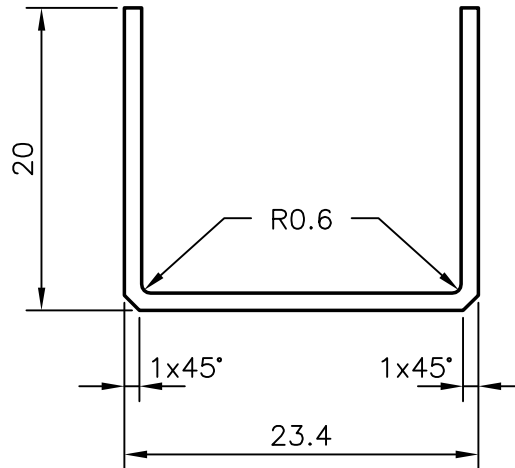

1. GENERAL WALL THICKNESS :- 1.13 mm.
2. WEIGHT PER PIECE :- 0.650 kgs. TO 0.700 kgs.

JINDAL ALUMINIUM LTD.

BANGALORE-560073

<i>JINDAL ALUMINIUM LTD.</i>		NAME	DATE
		DRAWN	R.D.Sharma 13-04-98
1. ALL DIMENSIONS ARE IN mm. 2. ROUND OFF ALL SHARP CORNERS WITH 0.4 mm. 3. TOLERANCES WILL BE AS PER IS: 3965-1981 ,UNLESS OTHERWISE SPECIFIED		CHECKED	
		APPROVED	
		SCALE	2:1
PARTY'S NAME	GENERAL CATEGORY	WEIGHT kg/m	0.184
PARTY'S DRAWING No.	NIL	SECTION No.	17545
ALLOY & TEMPER	HE9 WP	DRAWING No.	
LENGTH	3658 mm.	17545	
DESCRIPTION	MISCELLANEOUS CHANNEL		