

3931-ISSUE-2

17549

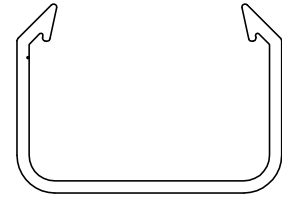

1:1

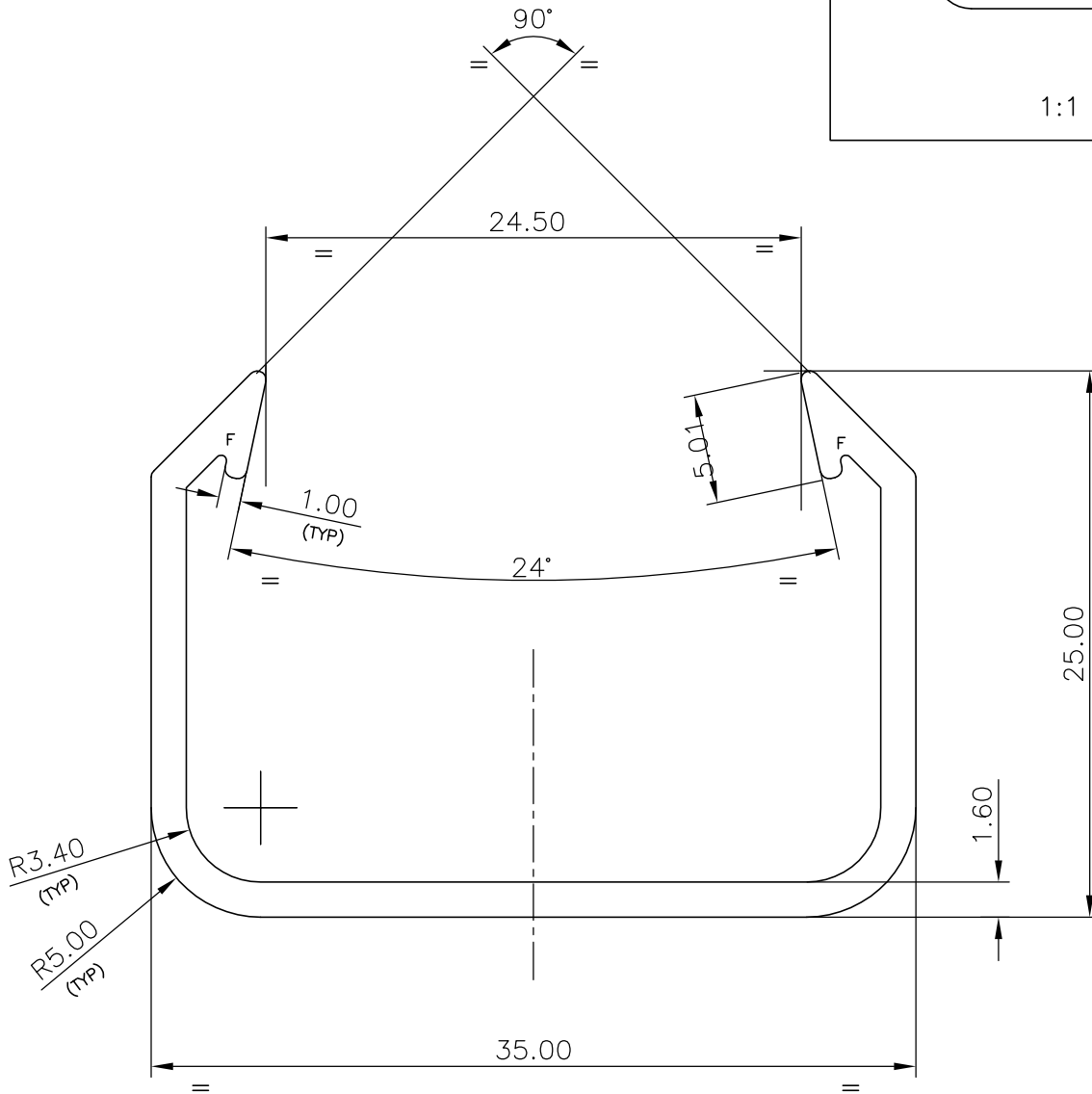

UNSPECIFIED WALL THICKNESS 1.60 mm

F = 0.25 RADII (2 Nos)

JINDAL ALUMINIUM LTD.
BANGALORE-560073

	NAME	DATE
DRAWN	P,KULKARNI	15-4-99
CHECKED		
APPROVED		

1. ALL DIMENSIONS ARE IN mm.
2. ROUND OFF ALL SHARP CORNERS WITH 0.4 mm.
3. TOLERANCES WILL BE AS PER IS: 3965-1981 ,UNLESS OTHERWISE SPECIFIED

PARTY'S NAME	RADHA SOAMI SATSANG, BEAS	SCALE	3:1
PARTY'S DRAWING No.	AS PER SAMPLE	WEIGHT kg/m	0.360
ALLOY & TEMPER	HE9 WP	SECTION No.	17549
LENGTH	AS REQUIREMENT	DRAWING No.	17549
DESCRIPTION	SOLID PROFILE		