

3934

17552

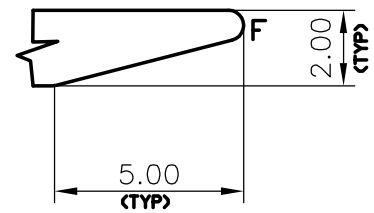

DETAILS A
5:1

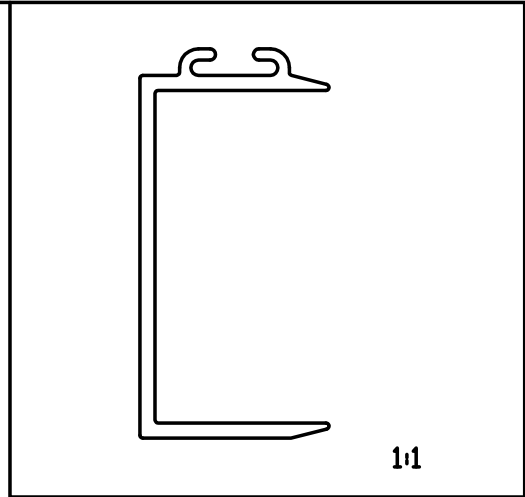
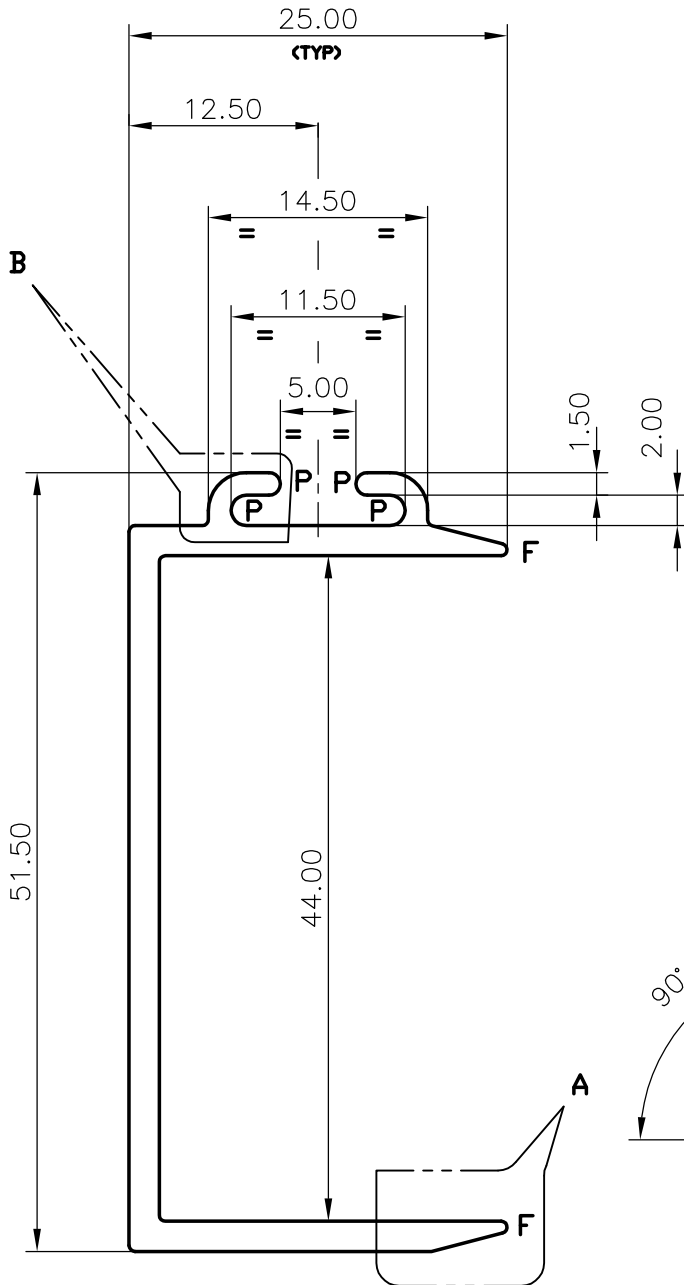
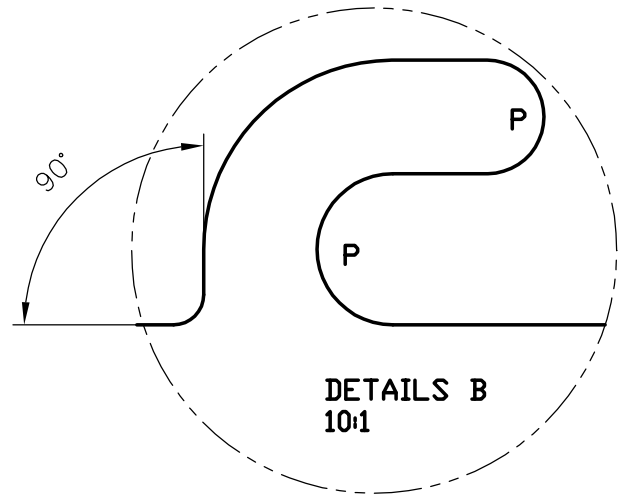

DETAILS B
10:1

P= FULL RADII (4)

F=RADII 0.40 (2)

GENERAL WALL THICKNESS = 2.00 mm

JINDAL ALUMINIUM LTD.
BANGALORE-560073

	NAME	DATE
DRAWN	P,KULKARNI	9-3-99
CHECKED		
APPROVED		
SCALE	2:1	
WEIGHT kg/m	0.538	
SECTION No.	17552	
DRAWING No.	17552	

1. ALL DIMENSIONS ARE IN mm.
2. ROUND OFF ALL SHARP CORNERS WITH 0.4 mm.
3. TOLERANCES WILL BE AS PER IS:3965-1981 ,UNLESS OTHERWISE SPECIFIED

PARTY'S NAME	GENERAL CATEGORY (DELHI MARKET)
PARTY'S DRAWING No.	AS PER SKETCH
ALLOY & TEMPER	HE9 WP
LENGTH	4267 mm. (14')
DESCRIPTION	STRUCTURAL MISCELLANEOUS