

P-4720

3995

17594

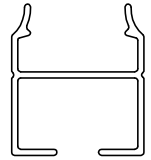

SCALE 1:1

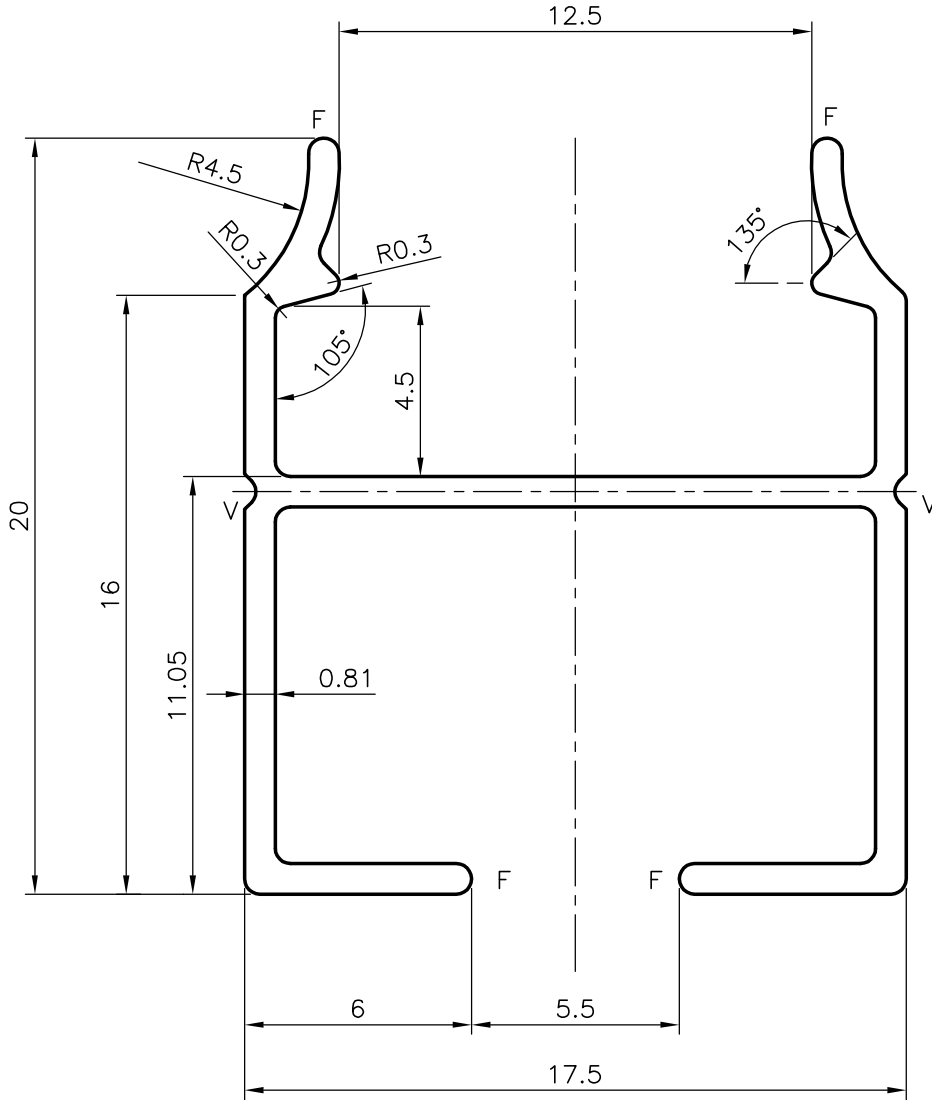

GENERAL WALL THICKNESS = 0.81mm

V = VEE GROOVE 0.3x90° (2 PLACES)



SYMBOL OF QUALITY
AN ISO 9002 COMPANY

JINDAL ALUMINIUM LTD.
BANGALORE-560073 (INDIA)

	NAME	DATE
DRAWN	RAGHAVENDRA	07-02-2004
CHECKED		
APPROVED		

1. ALL DIMENSIONS ARE IN mm.
2. ROUND OFF ALL SHARP CORNERS WITH 0.40 mm.
3. TOLERANCES WILL BE AS PER IS:3965-1981 UNLESS OTHERWISE SPECIFIED

SCALE	5:1
AREA mm ²	55.909
PERIMETER mm.	135.681
WEIGHT kg/m	0.150

PARTY'S NAME	GENERAL CATEGORY BANGALORE MARKET
PARTY'S DRAWING No.	LIGHTER SECTION OF 3962
ALLOY & TEMPER	HE9 WP
DESCRIPTION	MISC. CHANNEL

DRAWING No.	SECTION No.
P-4720	-
3995	3995
17594	17594