

3937

17604

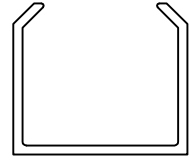

1:1

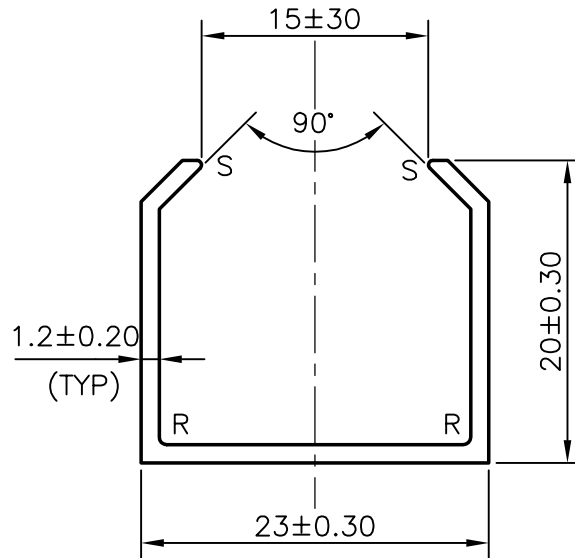

R = 0.50 RADIUS (2)

S = 0.30 RADIUS (2)

**JINDAL ALUMINIUM LTD.****BANGALORE-560073**

NAME

DATE

DRAWN

R.D.Sharma

08.06.99

CHECKED

APPROVED

1. ALL DIMENSIONS ARE IN mm.  
 2. ROUND OFF ALL SHARP CORNERS WITH 0.4 mm.  
 3. TOLERANCES WILL BE AS PER BS: 1474-1987 ,UNLESS OTHERWISE SPECIFIED

PARTY'S NAME

BETA INDUSTRIAL EST., DUBAI

SCALE

2:1

PARTY'S DRAWING No.

NIL

WEIGHT kg/m

0.204

ALLOY &amp; TEMPER

6063 T6 (HE9 WP)

SECTION No.

17604

LENGTH

5850 mm.

DRAWING No.

DESCRIPTION

MISCELLANEOUS CHANNEL

17604