

P-4547

17605

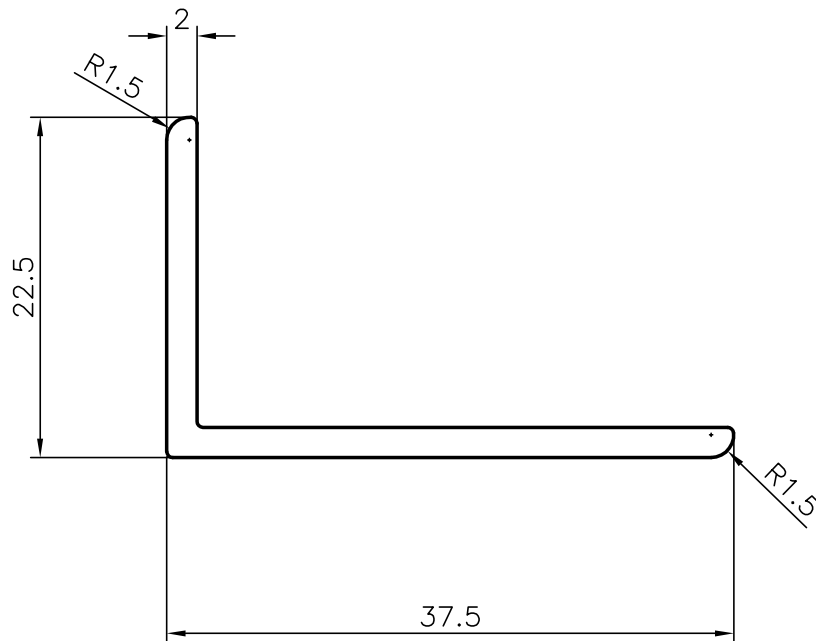

1:1



SYMBOL OF QUALITY  
AN ISO 9001 COMPANY

**JINDAL ALUMINIUM LTD.**  
BANGALORE-560073 (INDIA)

	NAME	DATE
DRAWN	MALINGAPPA	06-11-03
CHECKED		
APPROVED		
SCALE		2:1
AREA mm <sup>2</sup>		115
PERIMETER mm.		118
WEIGHT kg/m		0.310
DRAWING No.	SECTION No.	
P-4547	-	
17605	17605	

1. ALL DIMENSIONS ARE IN mm.
2. ROUND OFF ALL SHARP CORNERS WITH 0.40 mm.
3. TOLERANCES WILL BE AS PER BS:1474-1987 UNLESS OTHERWISE SPECIFIED

PARTY'S NAME	ASIAN HARDWARE (PTE) LTD., COLOMBO
PARTY'S DRAWING No.	AS PER SAMPLE
ALLOY & TEMPER	HE9 WP
DESCRIPTION	INFOI IAI ANGI F