

P-5106

17607

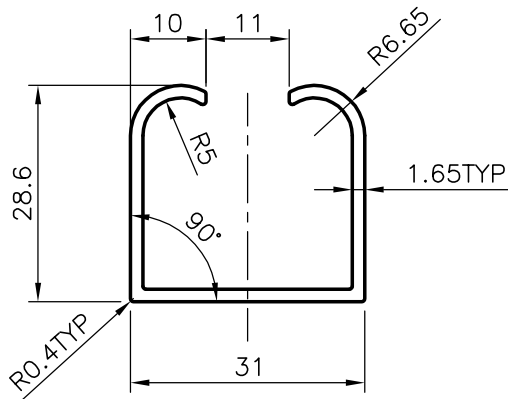

GENERAL WALL THICKNESS = 1.65mm



SYMBOL OF QUALITY  
AN ISO 9001 COMPANY

**JINDAL ALUMINIUM LTD.**  
BANGALORE-560073 (INDIA)

	NAME	DATE
DRAWN	RAGHAVENDRA	16-10-2004
CHECKED		
APPROVED		
SCALE		1:1
AREA mm <sup>2</sup>		159.842
PERIMETER mm.		195.99
WEIGHT kg/m		0.432
DRAWING No.	SECTION No.	
P-5106	-	
17607	17607	

1. ALL DIMENSIONS ARE IN mm.
2. ROUND OFF ALL SHARP CORNERS WITH 0.40 mm.
3. TOLERANCES WILL BE AS PER BS:1474-1981 UNLESS OTHERWISE SPECIFIED

PARTY'S NAME	SAFINAT AL. SAHRAA TRADING CO. LLC, DUBAI, U.A.E.
PARTY'S DRAWING No.	AS PER SAMPLE
ALLOY & TEMPER	6063 T6
DESCRIPTION	MISC. CHANNEL