

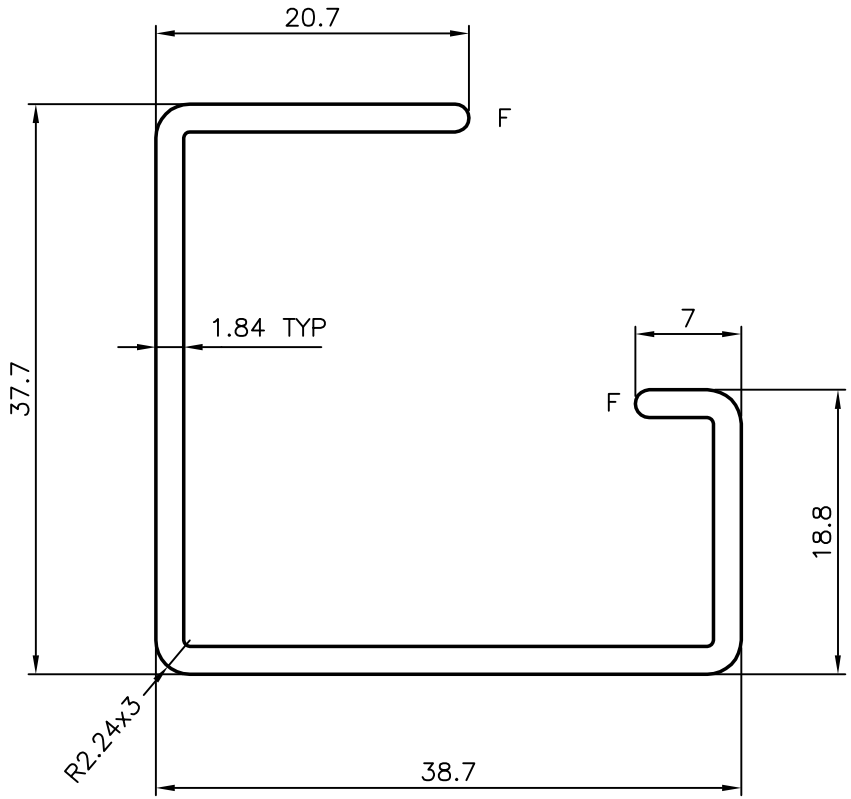

| |
|--------|
| P-5466 |
| 17609 |
| |

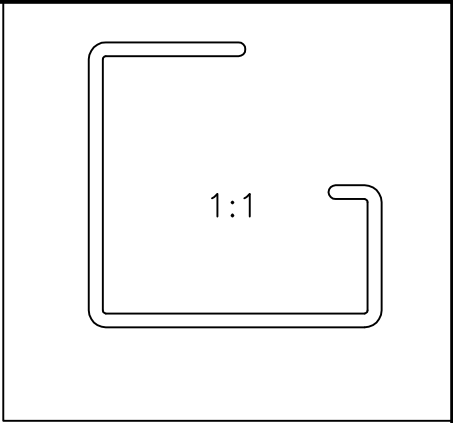

AVERAGE WEIGHT:- 2.052 kg/3658 mm

F = FULL RADIUS (2 PLACES)

| | | | | |
|--|--|----------------------|------------|-------------|
|  SYMBOL OF QUALITY AN ISO 9001 COMPANY | JINDAL ALUMINIUM LTD. BANGALORE-560073 (INDIA) | NAME | | DATE |
| | | DRAWN | MALINGAPPA | 27-04-2005 |
| 1. ALL DIMENSIONS ARE IN mm. 2. ROUND OFF ALL SHARP CORNERS WITH 0.40 mm. 3. TOLERANCES WILL BE AS PER IS:3965-1981 UNLESS OTHERWISE SPECIFIED | | CHECKED | | |
| | | APPROVED | | |
| PARTY'S NAME GENERAL CATEGORY, KOLKATA MARKET | | SCALE | | 2:1 |
| | | AREA mm ² | | 207.697 |
| PARTY'S DRAWING No. AS PER SAMPLE/WEIGHT | | PERIMETER mm. | | 228.648 |
| | | WEIGHT kg/m | | 0.561 |
| ALLOY & TEMPER HE9 WP | | DRAWING No. | | SECTION No. |
| | | P-5466 | | - |
| DESCRIPTION MISCELLANEOUS SECTION | | 17609 | | 17609 |
| | | | | |