

P-5501-1

17611

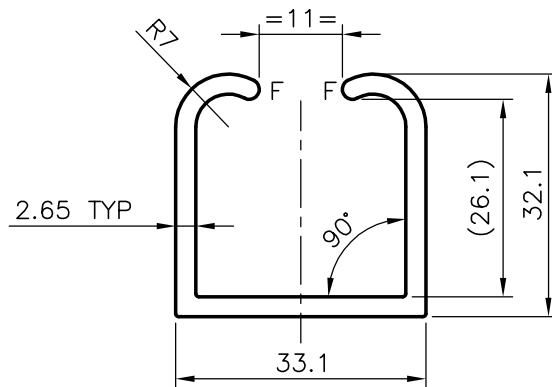

F = FULL RADIUS (2 PLACES)

GENERAL WALL THICKNESS = 2.65mm



SYMBOL OF QUALITY
AN ISO 9001 COMPANY

JINDAL ALUMINIUM LTD.
BANGALORE-560073 (INDIA)

	NAME	DATE
DRAWN	MALINGAPPA	24-05-2005
CHECKED		
APPROVED		

1. ALL DIMENSIONS ARE IN mm.
2. ROUND OFF ALL SHARP CORNERS WITH 0.40 mm.
3. TOLERANCES WILL BE AS PER IS:3965-1981 UNLESS OTHERWISE SPECIFIED

SCALE	1:1
AREA mm ²	274.526
PERIMETER mm.	210.665
WEIGHT kg/m	0.741

PARTY'S NAME	GENERAL CATEGORY, MUMBAI MARKET	DRAWING No.	SECTION No.
PARTY'S DRAWING No.	AS PER SAMPLE	P-5501-1	-
ALLOY & TEMPER	HE9 WP	17611	17611
DESCRIPTION	MISC. CHANNEL		