

P-5773

17617

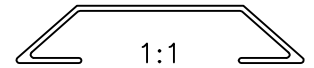

F = FULL RADII (2 PLACES)

GENERAL WALL THICKNESS = 0.70 mm

WEIGHT PER 3658 mm. LONG PIECE:- 0.409 kg (AVERAGE)

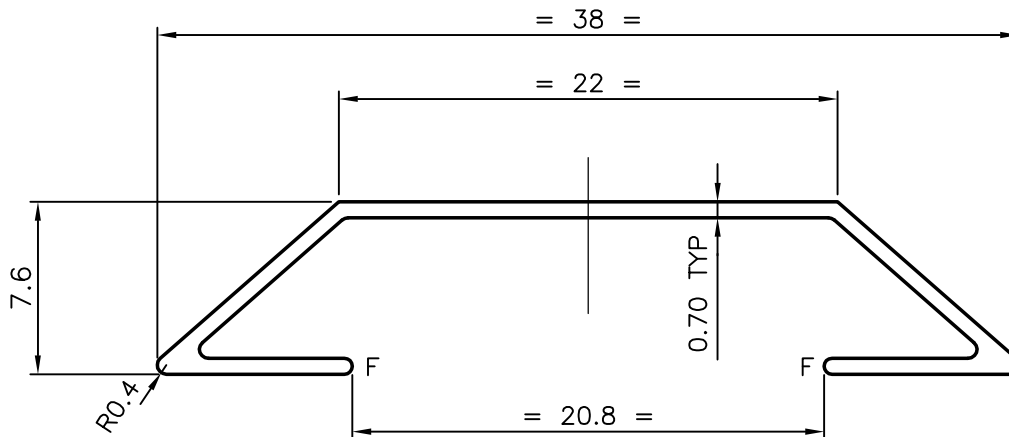

SYMBOL OF QUALITY
AN ISO 9001 COMPANY

JINDAL ALUMINIUM LTD.
BANGALORE-560073 (INDIA)

	NAME	DATE
DRAWN	MALINGAPPA	09-08-2005
CHECKED		
APPROVED		

1. ALL DIMENSIONS ARE IN mm.
2. ROUND OFF ALL SHARP CORNERS WITH 0.40 mm.
3. TOLERANCES WILL BE AS PER IS:3965-1981 UNLESS OTHERWISE SPECIFIED

SCALE	3:1
AREA mm ²	41.429
PERIMETER mm.	114.801
WEIGHT kg/m	0.112

PARTY'S NAME	GENERAL CATEGORY, DELHI MARKET
PARTY'S DRAWING No.	AS PER SAMPLE
ALLOY & TEMPER	HE9 WP
DESCRIPTION	MISCELLANEOUS SECTION

DRAWING No.	SECTION No.
P-5773	-
17617	17617