

P-5992

17621

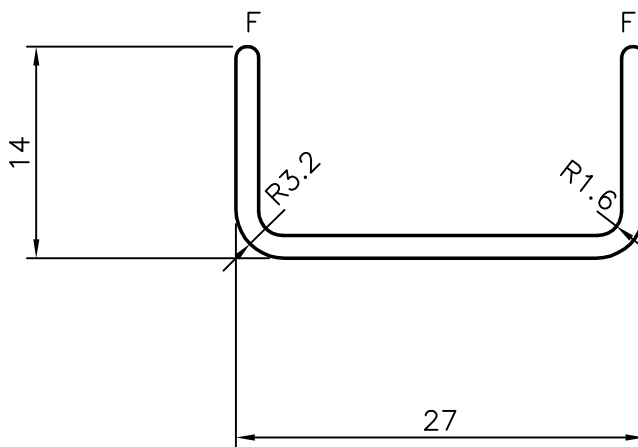

GENERAL WALL THICKNESS 1.50mm

F= FULL RADIUS



SYMBOL OF QUALITY
AN ISO 9001 COMPANY

JINDAL ALUMINIUM LTD.
BANGALORE-560073 (INDIA)

	NAME	DATE
DRAWN	J.P.KAUSHIK	25-11-2005
CHECKED		
APPROVED		

1. ALL DIMENSIONS ARE IN mm.
2. ROUND OFF ALL SHARP CORNERS WITH 0.40 mm.
3. TOLERANCES WILL BE AS PER IS:3965-1981 UNLESS OTHERWISE SPECIFIED

SCALE	2:1
AREA mm ²	74.221
PERIMETER mm.	101.592
WEIGHT kg/m	0.200

PARTY'S NAME	GENERAL CATEGORY.,MADURAI MARKET
PARTY'S DRAWING No.	AS PER SKETCH
ALLOY & TEMPER	HE9 WP
DESCRIPTION	CHANNEL

DRAWING No.	SECTION No.
P-5992	
17621	17621