

P-6268

17622

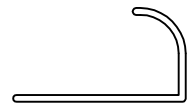

1:1

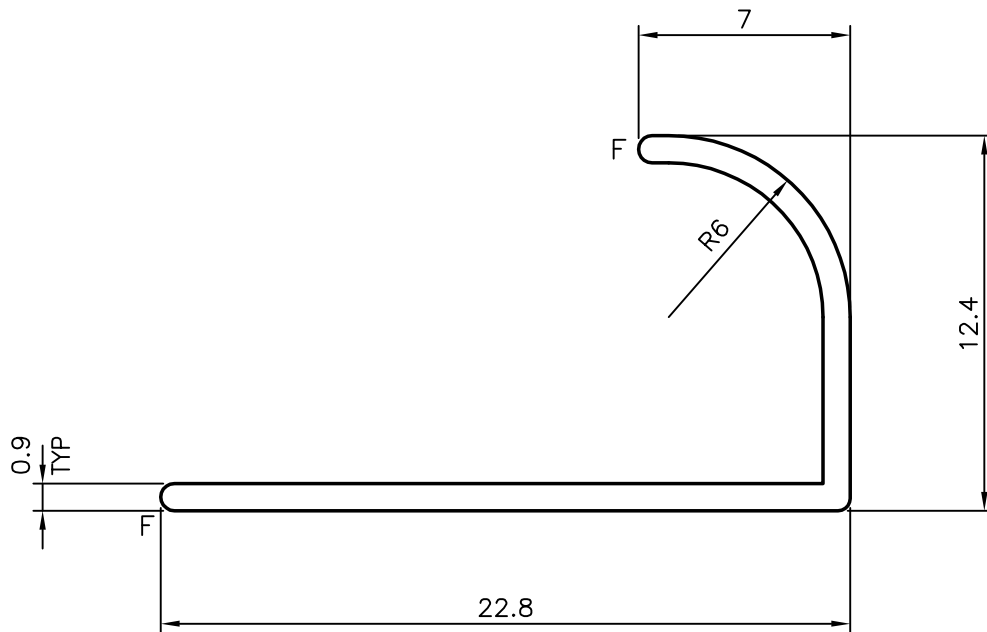

GENERAL WALL THICKNESS 0.90 (TYP)

F=FULL RADIUS (2)



SYMBOL OF QUALITY  
AN ISO 9001 COMPANY

**JINDAL ALUMINIUM LTD.**  
BANGALORE-560073 (INDIA)

	NAME	DATE
DRAWN	J.P.KAUSHIK	17-03-2006
CHECKED		
APPROVED		
SCALE		4:1
AREA mm <sup>2</sup>		34.008
PERIMETER mm.		76.892
WEIGHT kg/m		0.092
DRAWING No.		SECTION No.
P-6268		-
17622		17622

1. ALL DIMENSIONS ARE IN mm.
2. ROUND OFF ALL SHARP CORNERS WITH 0.50 mm.
3. TOLERANCES WILL BE AS PER BS:1474-1987 UNLESS OTHERWISE SPECIFIED

PARTY'S NAME	ASIAN HARDWARE (PTE) LTD.,SRILANKA
PARTY'S DRAWING No.	MS4049
ALLOY & TEMPER	6063 T6
DESCRIPTION	MISC. SECTION