

P-4850-2
S1213
17630

EXPOSED SURFACE
BETTER FINISH
REQUIRED

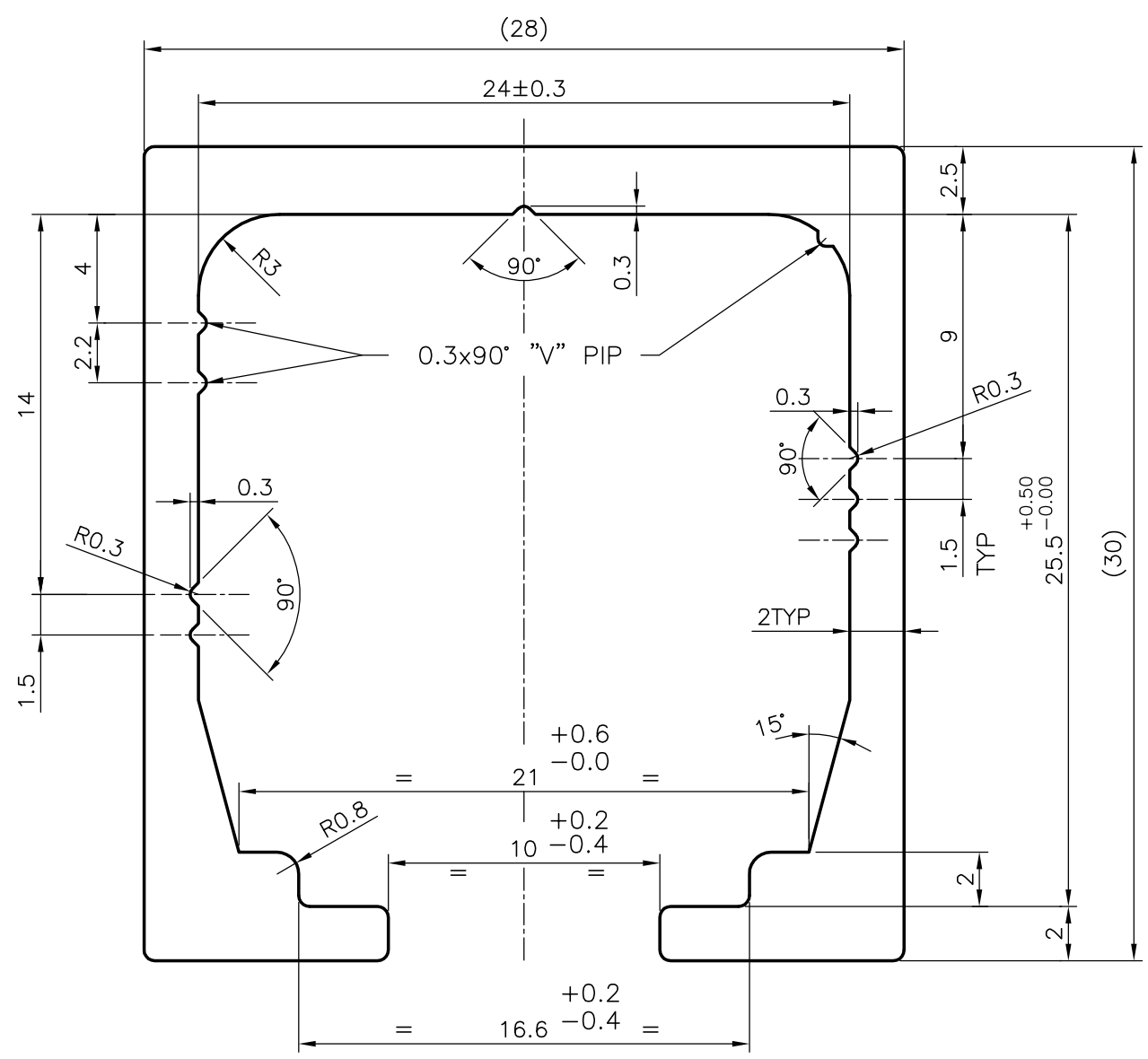
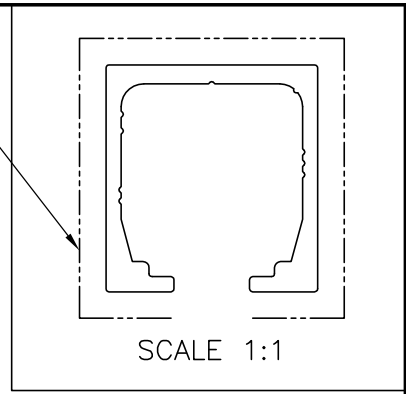

JINDAL ALUMINIUM LTD.
BANGALORE-560073 (INDIA)

	NAME	DATE
DRAWN	RAGHAVENDRA	14-05-2004
CHECKED		
APPROVED		

1. ALL DIMENSIONS ARE IN mm.
2. ROUND OFF ALL SHARP CORNERS WITH 0.40 mm.
3. TOLERANCES WILL BE AS PER IS:3965-1981 UNLESS OTHERWISE SPECIFIED

SCALE	4:1
AREA mm ²	234.089
PERIMETER mm.	193.396
WEIGHT kg/m	0.632

PARTY'S NAME	MALROX, MUMBAI
PARTY'S DRAWING No.	AS PER SAMPLE & AS PER REQUIREMENT
ALLOY & TEMPER	HE9 WP
DESCRIPTION	MISC. CHANNEL

DRAWING No.	SECTION No.
P-4850-2	-
S1213	S1213
17630	17630