

P-6761  
17638

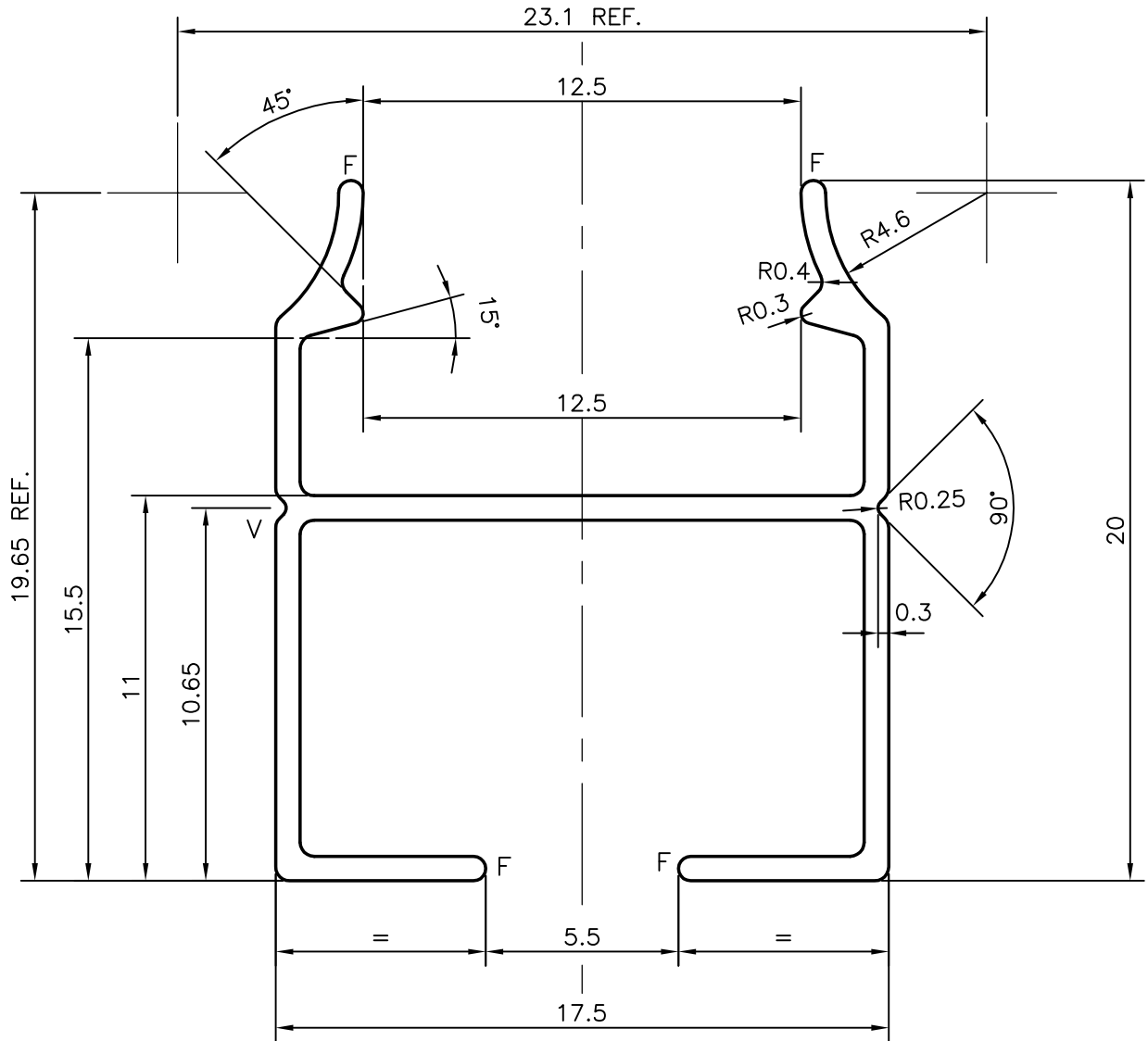

1. GENERAL WALL THICKNESS:- 0.70 mm.
2. F = FULL RADIUS (4)
3. V = 0.30x90° VEE GROOVE (2)

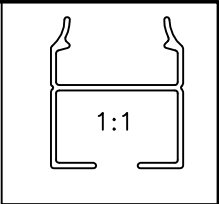

**JINDAL ALUMINIUM LTD.**  
BANGALORE-560073 (INDIA)

		NAME	DATE
DRAWN		R.D.Sharma	22-10-2006
CHECKED			
APPROVED			
SCALE			5:1
AREA mm <sup>2</sup>			49.545
PERIMETER mm.			136.94
WEIGHT kg/m			0.134
		DRAWING No.	SECTION No.
		P-6761	-
		17638	17638

1. ALL DIMENSIONS ARE IN mm. 2. ROUND OFF ALL SHARP CORNERS WITH 0.40 mm. 3. TOLERANCES WILL BE AS PER IS:3965-1981 UNLESS OTHERWISE SPECIFIED	
PARTY'S NAME	GENERAL CATEGORY, DELHI MARKET
PARTY'S DRAWING No.	LIGHTER OF SECTION NO. 17594
ALLOY & TEMPER	HE9 WP
DESCRIPTION	MISC. CHANNEL