

P-8751-1

17656

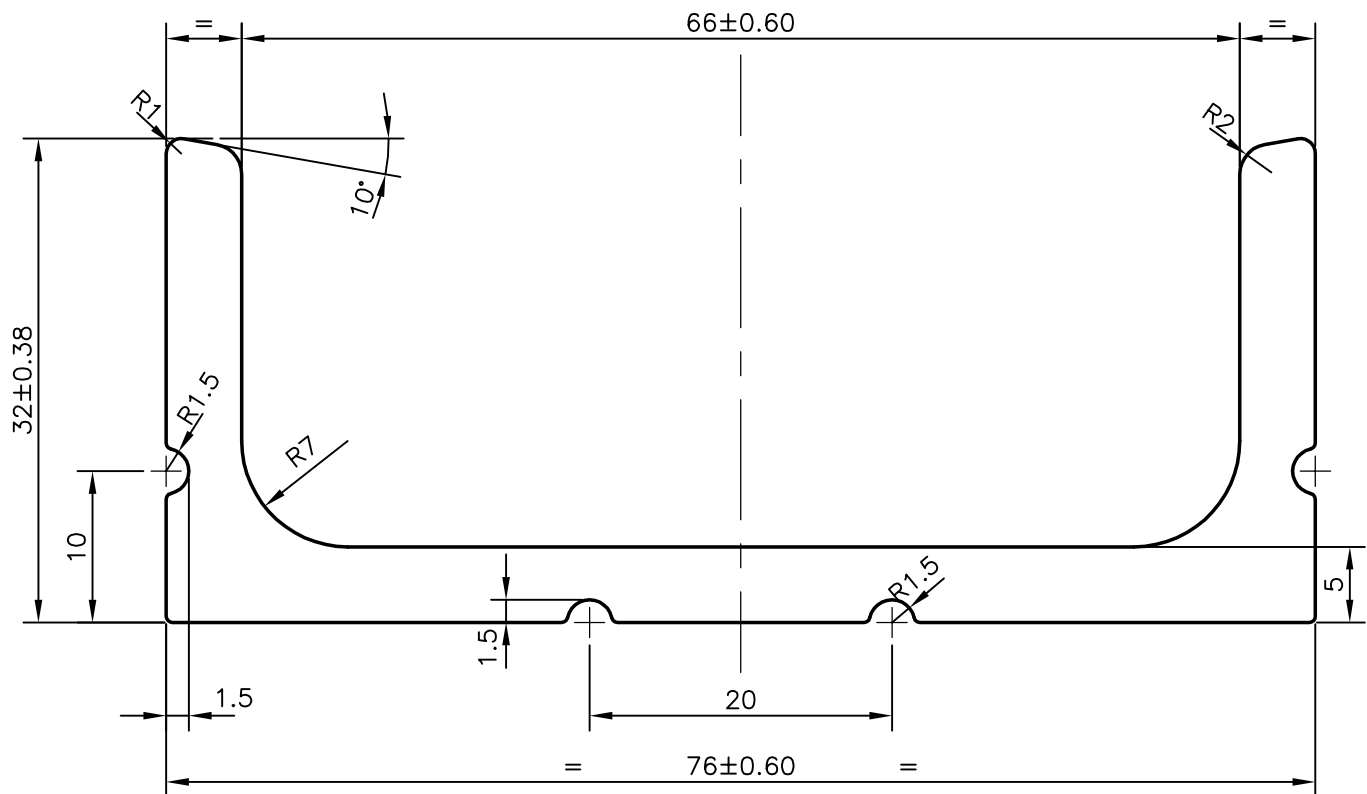

PLEASE NOTE:- CONVEXITY NOT ALLOWED

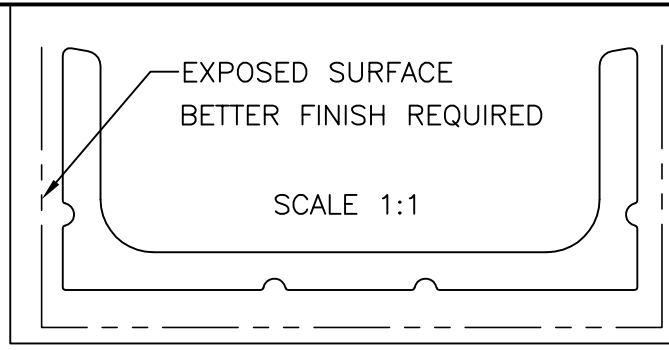

SYMBOL OF QUALITY
AN ISO 9001 COMPANY

JINDAL ALUMINIUM LTD.
BANGALORE-560073 (INDIA)

	NAME	DATE
DRAWN	ABHARANI	29-10-2008
CHECKED		
APPROVED		

SCALE	2:1
AREA mm ²	652.375
PERIMETER mm.	266.194
WEIGHT kg/m	1.761

DRAWING No.	SECTION No.
P-8751-1	-
17656	17656
-	-

1. ALL DIMENSIONS ARE IN mm. 2. ROUND OFF ALL SHARP CORNERS WITH 0.4 mm. 3. TOLERANCES WILL BE AS PER IS:3965-1981 UNLESS OTHERWISE SPECIFIED	
PARTY'S NAME	NETRACK ENCLOSURES PVT. LTD., BANGALORE
PARTY'S DRAWING No.	AS PER DRAWING
ALLOY & TEMPER	HE9 WP
DESCRIPTION	MISC. CHANNEL