

P-10675

S2815

17694

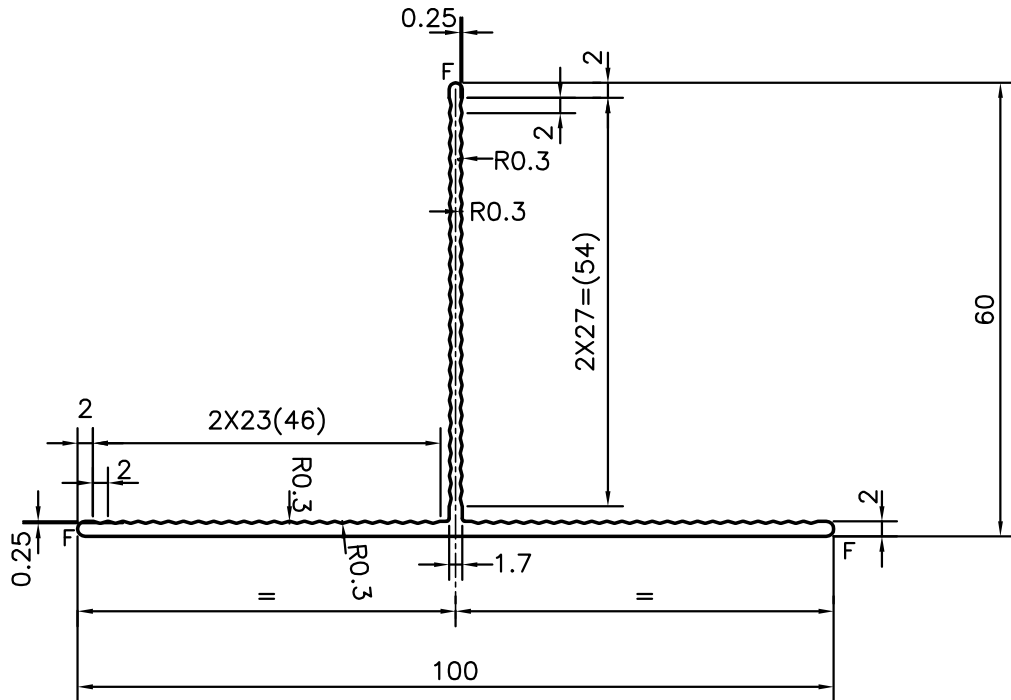

F = FULL RADIUS (3 PLACES)



SYMBOL OF QUALITY
AN ISO 9001 COMPANY

JINDAL ALUMINIUM LTD.
BANGALORE-560073 (INDIA)

	NAME	DATE
DRAWN	J.P.KAUSHIK	28-12-2010
CHECKED		
APPROVED	S.S.GARG	30-12-2010
SCALE		1:1
AREA mm ²		272.5
PERIMETER mm.		323.695
WEIGHT kg/m		0.736
DRAWING No.	SECTION No.	
P-10675	-	
S2815	S2815	
17694	17694	

1. ALL DIMENSIONS ARE IN mm.
2. ROUND OFF ALL SHARP CORNERS WITH 0.40 mm.
3. TOLERANCES WILL BE AS PER, IS:3965-1981 UNLESS OTHERWISE SPECIFIED

PARTY'S NAME	G.P. BIRLA ASTRONOMICAL OBSERVATORY AND RESEARCH CENTRE, HYDERABAD
PARTY'S DRAWING No.	AS PER DRAWING
ALLOY & TEMPER	HE9 WP
DESCRIPTION	FLUTED T SECTION