

P-13150

17704

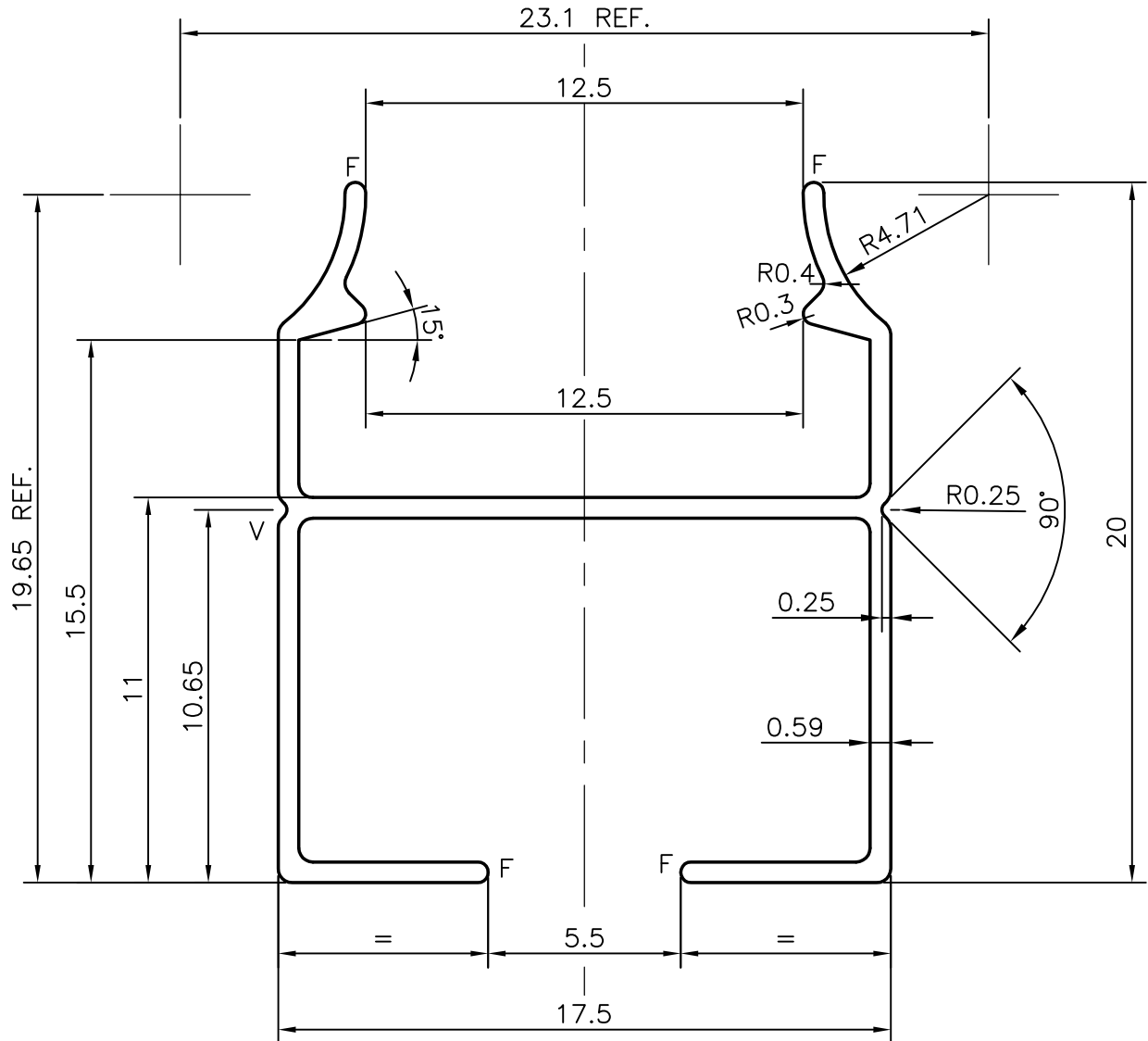

1. GENERAL WALL THICKNESS:- 0.59 mm.
2. F = FULL RADIUS (4)
3. V = 0.30x90° VEE GROOVE (2)
4. 3658 mm, LONG PIECES IN 100 Kgs = 238 (AVERAGE)

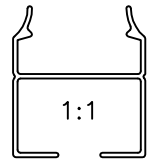

SYMBOL OF QUALITY
AN ISO 9001 COMPANY

JINDAL ALUMINIUM LTD.
BANGALORE-560073 (INDIA)

	NAME	DATE
DRAWN	RAGHAVENDRA	19-10-2013
CHECKED		
APPROVED	S.S.GARG	06-11-2013
SCALE		5:1
AREA mm ²		42.5
PERIMETER mm.		137.953
WEIGHT kg/m		0.115
DRAWING No.	SECTION No.	
P-13150	-	
17704	17704	

1. ALL DIMENSIONS ARE IN mm.
2. ROUND OFF ALL SHARP CORNERS WITH 0.40 mm.
3. TOLERANCES WILL BE AS PER IS:3965-1981 UNLESS OTHERWISE SPECIFIED

PARTY'S NAME	GENERAL CATEGORY, DELHI MARKET
PARTY'S DRAWING No.	LIGHTER OF SECTION NO. 17638
ALLOY & TEMPER	HE9 WP
DESCRIPTION	MISC. CHANNEL